

PAPER • OPEN ACCESS

Development of a mobile livestock loading ramp

To cite this article: Y Mijinyawa *et al* 2020 *IOP Conf. Ser.: Earth Environ. Sci.* **445** 012037

View the [article online](#) for updates and enhancements.

UNIVERSITY OF IBADAN LIBRARY

Development of a mobile livestock loading ramp

Y Mijinyawa¹, A A Asiru¹, S C Olaogun² and R A M Adedokun²

¹Department of Agricultural and Environmental Engineering, University of Ibadan

²Department of Veterinary Medicine, University of Ibadan

Corresponding Author: ayorinde.asiru@gmail.com

Abstract. An Adjustable Mobile Loading Ramp was developed to serve as panacea to the inadequacy of handling equipment along the cattle value chain in Nigeria. The Ramp is 2.7 m long and 1.0 m wide. Performance evaluation of the ramp was carried out based on the animal stress indicators i.e. pulse and respiratory rates measured before and after loading. For comparison, similar data were collected when loading was done manually at the Akinyele Cattle Market in Ibadan, Nigeria. The mean pulse rates (beats per minute) of animals before and after loading were 65.67 and 72.33 units respectively for the ramp as against 68.67 and 89 units for the manual method respectively. The mean respiratory rates (breaths per minute) before and after loading were 30 and 34.66 units respectively for the ramp compared to 29 and 45.67 units for the manual method respectively. Statistical analyses showed that there were no significant differences between the pulse and respiratory rates before and after loading of animals using the ramp. The manual method resulted in significant differences between the pulse and respiratory rates before and after loading. The use of the ramp eliminates many of the hazards associated with loading and unloading of animals onto transport vehicles.

1. Introduction

In developing countries such as Nigeria, the loading and unloading of animals is accomplished by dragging and battering the animals into the transport vehicles which result in severe injuries to the animals [1]. The level of cruelty the animals are subjected to by this loading practice comes to the fore when it is realized that an animal might be traded five to seven times from the farm where it is raised before reaching the slaughter slab [2]. Over the years, due to the lack of loading and unloading facilities, workers at abattoirs and livestock markets have devised certain practices that are used to load and unload the animals [3]. The practice adopted depends on the type of vehicle used for conveying the animals. One of the major vehicles used for conveying animals is pick up. For this kind of vehicle, three men are required to load and unload animals from it as shown in Plate 1. During the process of loading and unloading animals from pick-ups, animals usually experience excruciating pain [4].





Plate 1: Typical Cattle Loading Method onto a Pick-up Van

There are risks involved in handling of large animals such as cattle. As such, equipment and facilities that improve handler's comfort and security, as well as improve the ease of handling animals are very important during handling operations [5] and [6]. This highlights the importance of a facility such as the loading ramp for loading and unloading of livestock. The Health and Safety Authority [7] had reported that most injuries to handlers occur during loading and unloading of cattle many of which could be avoided by using ramps.

To ameliorate the problems associated with loading and unloading of cattle onto a transport vehicle, this work was carried out to develop an adjustable mobile ramp that could be used with livestock transport vehicle of various floor heights.

2. Material and Methods

2.1 Design Considerations:

The ramp is expected to be mobile, and have adjustable height to suit all animal transport vehicles. Four factors were considered during the design process of the ramp. These were the floor heights of the livestock transportation vehicle (0.5 to 1.2 m), the average body weight (550 kg), hoof pressure (0.203 N mm^{-2}) of the cow [1] and the materials of construction (timber, steel pipes and angle iron) that are suitable and readily available. The ramp comprised of five essential components (the deck, the L-angle beams, the steel column, the wheels and the side screen) as shown in figure 1 and 2.

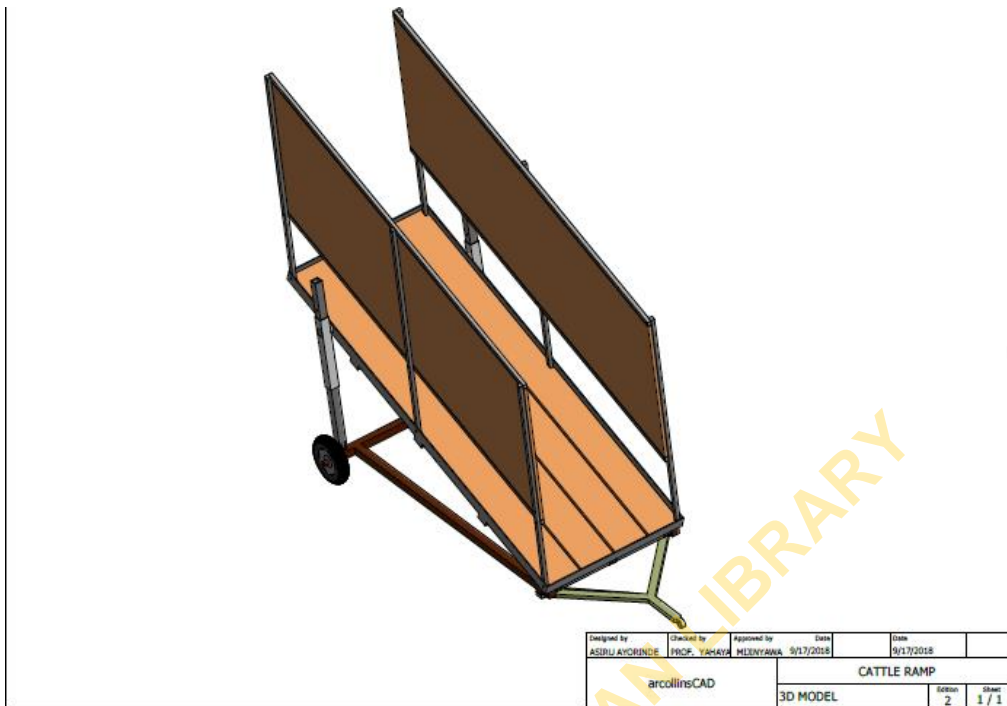

Figure 1: 3D model of the Ramp

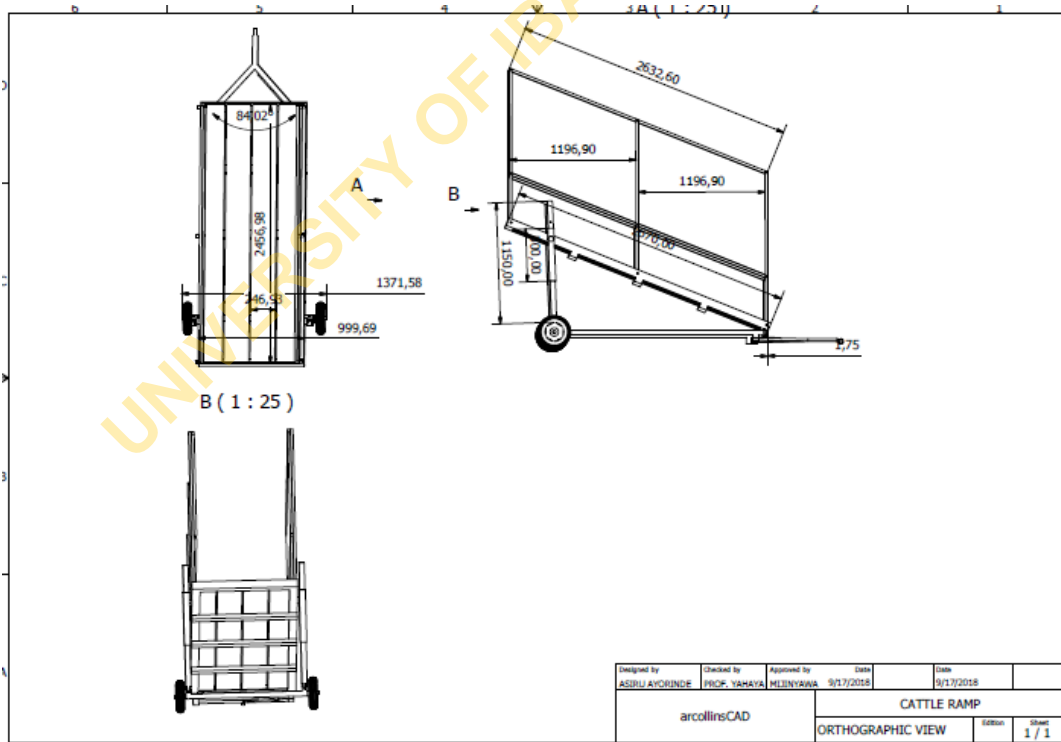

Figure 2: Orthographic projection of the ramp

2.2 Components Design and Materials Selection

2.2.1. The Deck. Depending on the floor height of the vehicle, the length of the deck could vary from as low as 1.93 m to as high as 2.74 m. In this work, the maximum length (2.74 m) was selected for design. A width of 1.0 m was selected for the deck to allow the animal move freely in only one direction without turning. The hoof stress of the cow on the ramp was assumed to be uniformly distributed load over the surface of the deck considering that the animal could step on any most of the surface of the deck when walking through the ramp. The deck was considered as a beam built in at both ends and under a uniformly distributed load. Possible dimensions of the deck thickness were selected and tested for bending, shear and deflection as failure criteria using standard formulae as stated by Mijinyawa [8] thickness of 8 mm was found adequate. However, considering the cost of making special order for that thickness of timber, the least readily available thickness of 25 mm was recommended for the deck thickness.

2.2.2. The L-angle Beam. The L-angle beams support the live load (body weight of the animal) and the dead load (self-weight of the wooden deck). They were designed as simply supported beams supporting uniformly distributed load with a span of 2.74 m; possible dimensions of the L-angle beam were selected and tested for bending, shear and deflection as failure criteria using standard formulae as stated by [8] and a section of 76.2 mm × 76.2 mm × 3.2 mm thickness was found adequate.

2.2.3. The Steel Columns. The steel columns are crucial components of the loading ramp as they support the decks and make the height variations possible. It also supports the entire weight of the mobile ramp. It was assumed that each of the two rear steel columns supports 50% of the total weight of the ramp and the live load. Dimensions for the columns were selected and tested for buckling as failure criteria using standard formulae from Vazirani et. al. [9] and a square hollow pipe of external dimensions 31.8 mm × 31.8 mm and thickness of 3.2 mm was found adequate.

2.2.4. The Wheels. The wheels for the loading ramp were standard wheel barrow tyres with wheel diameter of 40 cm and width of 10 cm with load capacity of 160 Kg. They were found adequate in bearing the load to which the loading ramp is to be subjected.

2.2.5. The Side Screens. The side screens are primarily non-load bearing members and were constructed out of 12 mm plywood which were bolted onto square hollow pipes of external dimensions 31.8 mm × 31.8 mm and thickness of 3.2 mm. The steel pipes were welded onto the L-angle beams.

2.3. Fabrication process

The construction of the mobile loading ramp was carried out at the Faculty of Technology, University of Ibadan Central Workshop. The construction started from the L-angle frame on which the wooden deck is to be laid. The L-angle frame was thereafter attached with hinges to the support frame for the columns. The wheelbarrow wheels were subsequently attached onto the supporting frame. The steel columns were drilled and bolted onto the supporting frame. The short superimposed square tubes were drilled and then welded onto the L-angle frame and the columns inserted into them to complete the steel frame of the ramp. The wooden deck was thereafter laid. The guard rails were then welded onto the L-angle frames and the plywood were attached to the guard rails.

2.4. Performance evaluation of the ramp

The complete ramp was evaluated at the Dairy Unit of the University of Ibadan Teaching and Research Farm (7°27'26" N, 3°53'58" E). Plate 2 shows a cow walking through the ramp onto the trailer during the testing. The evaluation parameters were the structural integrity of the ramp and the comfort of animals.



Plate 2. A Cow walking through the adjustable loading Ramp

The pulse and respiratory rates of the animals which are indications of animal stress, were taken before the animals were loaded onto a trailer using the mobile adjustable ramp. Pulse rate were taken using a stethoscope. The respiratory rates of the animals were measured by observing the movement of the animals' ribcage on inhalation for 15s and the figure multiplied by 4 to give the respiratory rate per minute [10]. All measurements were taken in duplicates. The same parameters were obtained from the animals before and after loading using the traditional method at the Akinyele Cattle Market, Ibadan ($7^{\circ}36'19''$ N, $3^{\circ}54'57''$ E). The loading ramp was inspected for any sign of breakage or excessive deflection.

3. Results and Discussion

3.1. Structural Integrity of the Ramp

Visual observation of possible joint separation, component failure and excessive deflections was carried out while the testing was done. There was no evidence of any of these forms of failure confirming the structural integrity of the designed ramp.

3.2. Pulse rate

The results of the pulse rate measurements are presented in figure 1. There were increases in the pulse rates of the animals before and after loading using both the loading ramp and the manual method. However, the increase was generally more when the manual method was used. Eniolorunda, *et al* [3] explained that the higher pulse rate of an animal during loading is a mechanism indicating that the heat loss from the animal is through respiration and that greater energy is required by the animal during loading. According to Costa [11] and Abdisa *et. al.* [12], they reported that the level of the hormone cortisol could increase as a consequence of the physical effort and psychological stress due to loading. Increase in the hormonal cortisol level is known to cause increase in pulse and respiratory rates.

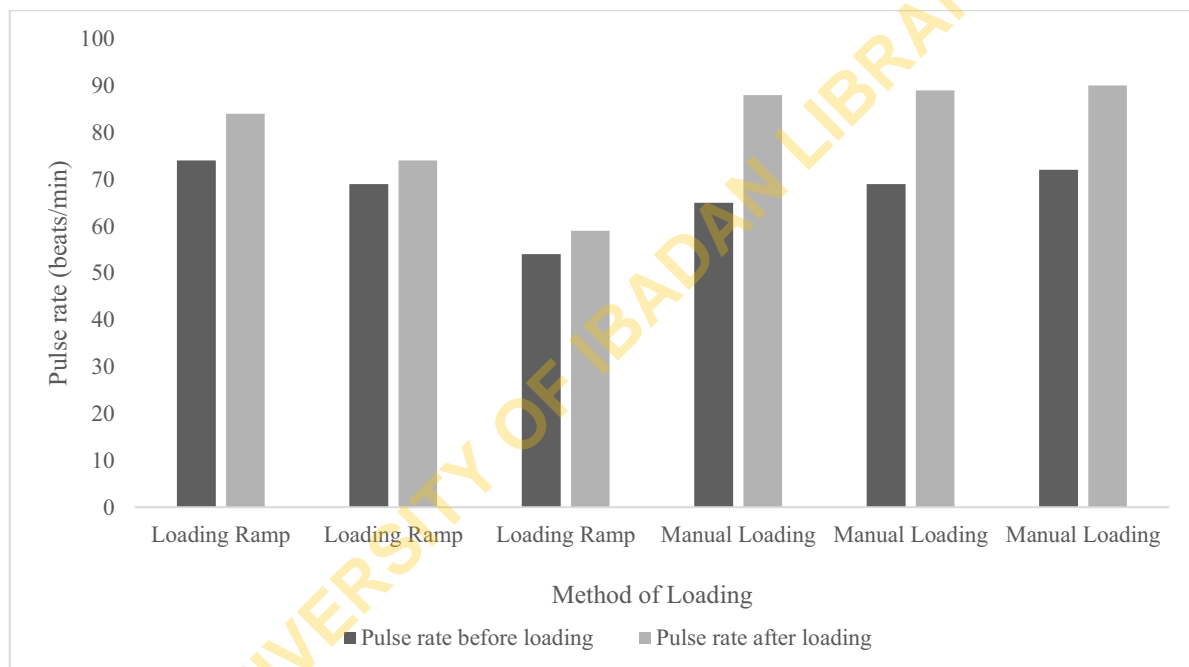

Figure 3: Pulse Rate of the Animals before and after Loading

The mean pulse rate before loading was 65.67 beats per min and rose to 72.33 beats per min after loading using the loading ramp. This slight increase could be attributed to the fact that one of the factors that influence the pulse rate of animals is exercise. The mean pulse rate before loading was 68.67 beats per min while the mean pulse rate was 89 beats per min after loading using the manual method. Statistical analysis (t-test) was carried out on the pulse rate of the animals loaded with the loading ramp and the manual method respectively using Microsoft Excel 2016. Results shows that the p-value for loading with the mobile ramp was 0.06 while it was 0.005 for manual loading. As such, there is no statistically significant difference between the pulse rates of the animals before and after loading using the ramp. It can therefore be concluded that the animals were subjected to minimal stress based on their pulse rates as specified by Eley [13]. And that, there is a statistically significant difference between the pulse rate of the animals before and after loading using the manual method of loading. It can therefore be concluded that the animals were subjected to more stress when loaded manually than when loaded using the ramp.

3.3 Respiratory rate as a measure of stress

The results of the respiratory rates are presented in Figure 4. There was an increase in the respiratory rates of the animals before and after loading using both the loading ramp and the manual method. However, higher respiratory rates were observed when manual method was used.

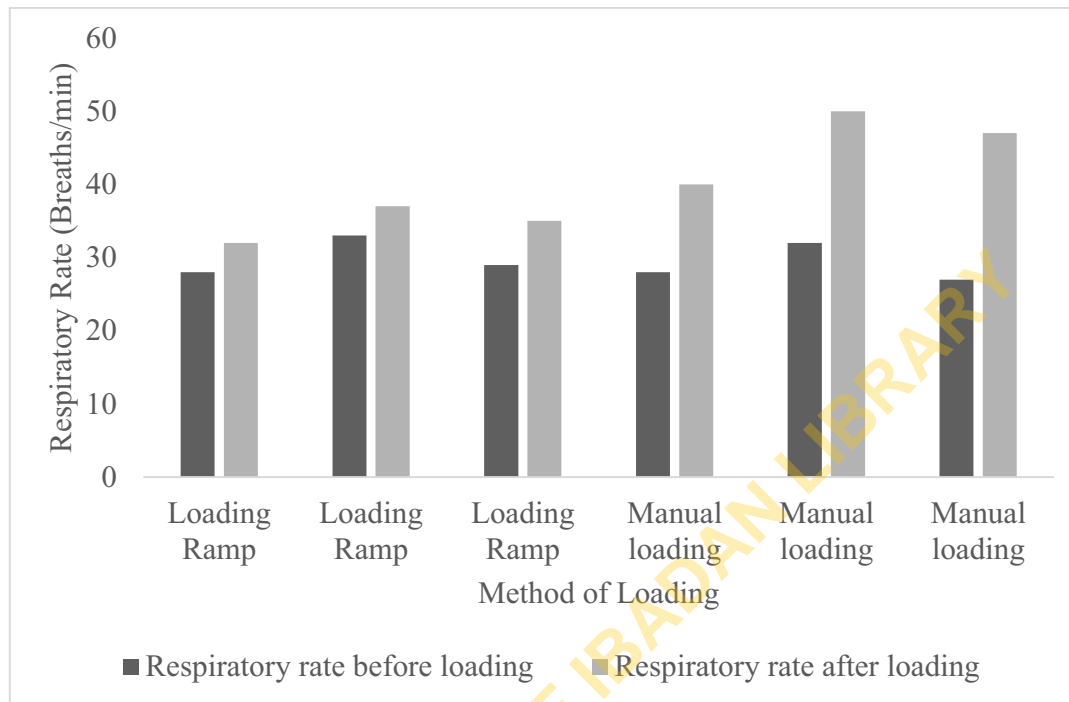

Figure 4. Respiratory Rate of the Animals before and after Loading

The mean respiratory rate was 30 breaths per min before loading and 34.66 breaths per min after loading using the adjustable ramp. T-test analysis conducted on the respiratory rate of animals loaded using the ramp gives a p-value of 0.09 which indicates that there is no significant difference in the respiratory rate of the animals before and after loading. The mean respiratory rate before loading was 29 breaths per min while the mean respiratory rate was 45.67 breaths per min after loading using the manual method. The result of the t-test analysis on the respiratory rate of animals loaded using the manual method gives a p-value of 0.02 signifying that there was a significant difference in the respiratory rate of the animals before and after loading. Based on this, the manual method has been found to be more stressful on the animals compared to the ramp.

4. Conclusion and Recommendation

A mobile livestock ramp for the loading and unloading of livestock into livestock transportation vehicles was designed, developed and tested. The designed ramp was constructed and tested using structural integrity of the ramp and animal comfort as criteria for assessment. The ramp was structurally stable and animals were not subjected to any stress in the course of loading as often experienced in the traditional loading method. The outcome of this work provides a viable method of loading livestock efficiently into livestock transportation vehicles with different floor heights. The use of the loading ramp designed reduced the drudgery on handlers while loading animals. It also reduces the physical pain the animals are subjected to when using the traditional method. The ramp designed and developed requires two people to adjust the height. However, hydraulic mechanisms could be incorporated into the ramp to improve its efficiency.

and also to minimise the drudgery in the user. It is therefore recommended that future designs should incorporate hydraulics. This will enable a single operator to use the ramp.

References

- [1] Mijinyawa, Y and Atanda, S. (2010). Design, Construction and Testing of Livestock Loading and Unloading Ramp. *Global Journal of Engineering and technology* **3** 2 301-8
- [2] Adamu A, Filani M and Mamman A A 2005 Market and Transport Institutions in Nigeria's Livestock Trade: Case Studies from Sokoto and Ibadan
- [3] Eniolorunda O O, O E Fashina and O O Aro 2009 Adaptive physiological response to load time stress during transportation of cattle in Nigeria. *Archivos de zootecnia* **58** 222
- [4] Grandin T 1997 Assessment of Stress during handling and transport *Journal of Animal Science* **75**
Retrieved from <http://www.grandin.com>
- [5] Broom, D.M. (2007). Causes of poor welfare and welfare assessment during handling and transport in Grandin ed. *In: Livestock Handling and Transport*. CAB International
- [6] Flint H E 2013 Load Characteristics and the Behaviour of Beef Cattle Unloaded for Feed, Water and Rest During Long Distance Transportation in Canada. Master of Science thesis, University of Guelph.
- [7] Health and Safety Authority 2011 Guidance on the Safe Handling of Cattles on Farms. Dublin: The Health and Safety Authority. <https://www.ifa.ie/wp-content/uploads/2013/10/HSA-Guidance-on-Safe-Handling-of-Cattle-on-Farms.pdf> (Retrieved online on 11/04/2018)
- [8] Mijinyawa Y 2012 *The Design of Farm Structures* (Ibadan: Ibadan University Press)
- [9] Vazirani, V N, Ratwani M M and Honey M 2010 Design and Analysis of Steel Structures (New Delhi: Khanna Publishers)
- [10] Maria G A, Villareol M, Chanchon G, Gebresenbet G 2004 Scoring system for Evaluating the stress to cattle of commercial loading and unloading *Vet Rec* **156** 26 818 –21
- [11] Costa L N 2009 Short-term stress: The Case of Transport and Slaughter *Italian Journal of Animal Science* **8** 1
- [12] Abdisa T 2017 Review on Practical Guidance of Veterinary Clinical Diagnostic Approach. *International Journal of Veterinary Science Research* **3** 2 6-25 DOI: [10.17352/ijvsr.000020](https://doi.org/10.17352/ijvsr.000020)
- [13] Eley T 2011 The Healthy Cow. Retrieved on February 18 2019 from <https://www.nadis.org.uk/disease-a-z/cattle/the-healthy-cow/>