

## Development of a Disuse Water Sachet Lacerating Machine; a Fibre Source for Cement Composite Production

Omoniyi, T. E. and Akano, D. I.

Department of Wood Products Engineering, Faculty of Technology,  
University of Ibadan

**ABSTRACT:** Disuse water sachet constitutes menace in developing countries; it is abundant, non-biodegradable and the disposal means are expensive, traditional and unhealthy. This paper reports the development of a machine capable of processing water sachets into fibres suitable for cement – composite production. The machine was designed to use fixed spikes and rotary sawing blades for shearing and lacerating the disuse sachets. The blades were rotated by a single phase 2hp electric motor at a speed of 1880 rpm transmitted by means of V-belt pulley system. The machine capacity and lacerating efficiency were 7.5kg/hr and 90.0%, respectively with a production cost of \$225. The portable machine is expected to reduce environmental problems and enhance cement – composite properties.

**KEYWORDS:** Water sachets, machine capacity, lacerating efficiency, cement composite

Date of Submission: 08-05-2020

Date of acceptance: 22-05-2020

### I. INTRODUCTION

Sachet water is a mineral water of about 0.5litres meant for human consumption. It is usually packaged and sold to members of the public in sealed nylons. It offers the cheapest and most accessible means of assuaging the feeling of thirst. During the dry season about 70 percent Nigeria adults drink at least one sachet of pure water daily indicating that about 60 million used sachet are thrown into the streets of the country on a daily basis (Edoga, 2008).

The University of Ibadan, in the light of satisfying this basic need set up pure water factory branded "UI WATER". This has made quality water readily available to everyone within the school premises. The brand has grown so popular causing even high demand for it outside the school. UI WATER presently plays a major role in the provision of drinkable water in the university. It has provided relief and comfort to lots of people who find it readily available, accessible and affordable to quench their thirst, whenever nature demands. It has also created lots of job opportunitiesto many people through the production and sales of the products.However, the used sachet is now a menace in the school just like all urban areas in Nigeria. Increase in the consumption of pure water has made the disposal of the sachets even tougher. The University of Ibadan with an estimated population of about 35,000 in 2015 and with each student taking an average of 2 sachets of pure water daily produces a total of 70,000 waste sachets to be disposed within the school environment on daily basis. These are indiscriminately dumped on the roads and gutters where they have a negative impact on the environment.

According to Odusoteet. al., (2012) the available disposal methods are traditional, expensive and unhealthy. Recycling of polyethylene materials is often seen as an effective and efficient management system as this will provide a sustainable solution to the environmental problems and will invariably lead to clean and aesthetic environments. However recycling of water sachet is not likely to be economically viable because of inks and dirt associated with sachets and the level of technological development and expert available for recycling in Nigeria would make it even more difficult to recycle according to Bainet. al. (2007).Properties of sachets such as stiffness, strength and toughness are decisive properties in industrial, technological and household applications. The properties make them convenient materials for matrix reinforcement such as polymer composites or fibre-cement applications (Adegokeet. al., 2013). This research targets the processing of disuse water sachets for use in cement composite production.

## II. MATERIALS AND METHODS

The materials used for lacerating machine include steel plates, black pipes, metallic bars, shafts, nails, bearings, pulleys and belts. The properties of disuse water sachet were determined

### Parts Design and Materials Selection

The factors which influence the choice of materials selected for the design include materials suitability, strength, local availability and cost effectiveness. The functional parts include the lacerating chamber, lacerating units, power units, main frame and outlet chute.

#### Lacerating chamber:

The raw feedstock is introduced through the lacerating chamber. Materials commonly used in lacerating chamber design are galvanized steel sheets, iron sheet metal and aluminium sheets. The aluminium sheets although expensive offer very good resistance to corrosion and have better angle of repose with plastic (water sachet). Galvanized steel sheets also have desirable corrosion resistance and thermally stable. Both vertical and horizontal forces are present in the lacerating chamber and act on the inside wall of the lacerating chamber. Since the operation will be carried out in batches, the size should be considerably smaller to increase efficiency; and also large enough to ensure a higher production rate.

#### Lacerating Unit:

It consists of the cutting sawing blades and the fixed spikes. The blades are turned by the shaft connected to the electric motor by the V- belt. Cutting is performed as the blade rotates over and above the fixed spikes. The faster the blade rotates the quicker and the better the cutting action. Since cutting needs to be performed as fast as possible, the blade has to be strong enough to withstand stresses. Also, material of high strength to weight ratio should be used. Commonly used materials are mild steel metal and iron metal. The mild steel offers desirable qualities and is hereby preferred over the iron metal while the spikes were made of nails welded to the selected portion of the base of the lacerating chamber.

#### Power Unit

It produces the electrical energy that drives the cutting blades. It consists of the following parts:

- i. Electric Motor: It produces the energy required to turn the shaft with in turn rotates the cutting blade. An electric motor of known power rating (hp) would be used. It is the main source of the rotational energy that is required to lacerate the sachets.
- ii. V-belt and Pulley: it transmits energy from the electric motor to the shaft. There are two pulleys - the larger pulley and the smaller pulley. The V-belt then connects the two pulleys. Rubber v-belts are most common and are very effective for the cutting operation. Pulleys available in Nigerian markets are usually made of cast iron; hence it is used in this project.
- iii. Shaft: It receives energy supplied from the electric motor through the v-belt and the pulley. The shaft would be 25mm in diameter and made of mild steel.

#### Outlet Chute and support stand

Lacerated materials are collected through the outlet chute located slightly below the cutting mechanism while the supportstand carries the whole weight of the structure. It also carries the vibration during operation and is expected to be relatively movable.

### Parts Design Analyses

Lacerating chamber: This contains the cutting sawing blades, the fixed spikes and raw feedstock, the design and construction are specified below: Fig. 1 specified the capacity estimation of the lacerating chamber

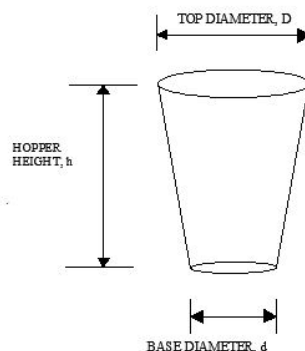

Fig. 1: Estimating the lacerating chamber capacity

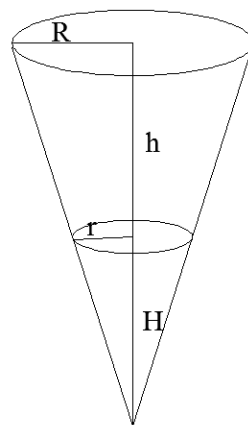

Fig. 2: The cone

From computation,

$$V = \frac{1}{3}\pi R^2(H + h) - \frac{1}{3}\pi r^2H \tag{1}$$

Using similar triangles relationship as shown in Fig. 2 the equation can be re-written as:

$$V = \frac{\pi h}{3}(R^2 + Rr + r^2) \tag{2}$$

where V = total volume of the lacerating chamber

D = top diameter

d = base diameter

h = lacerating chamber height

$$D = 30\text{cm} = 0.30\text{m}, \quad d = 25\text{cm} = 0.25\text{m}, \quad h = 30\text{cm} = 0.30\text{m}$$

$$V = \frac{\pi \times 0.3}{3} \left[ \left(\frac{0.3}{2}\right)^2 + \left(\frac{0.3}{2} \times \frac{0.25}{2}\right) + \left(\frac{0.25}{2}\right)^2 \right] = 0.01787\text{m}^3$$

Maximum amount of waste pure water sachet that can be lacerated at a time;

$$\rho = \frac{\text{mass}}{\text{volume}}$$

$$M = \rho \times V = 25 \times 0.02 = 500\text{g}$$

The capacity of the lacerating chamber is 500g which means size reduction of about 450 sachets is possible in a batch.

Angle of repose

Experimentally, the angle of free flow (repose) of water sachets on Iron metal sheet was found to be about 30°. This conforms to the standard set in "Material Characteristics Guide - Omega Engineering handbook" where nylon is described to have an angle of repose between 30 to 40°

Take  $\theta = 30^\circ$

$$K = \frac{1 - \sin\theta}{1 + \sin\theta} \tag{3}$$

Where K = Janssen coefficient for nylon ( $\cong 0.4$ )

$\theta$  = angle of repose

$$K = \frac{1 - \sin 30}{1 + \sin 30}$$

$$K = 0.33$$

Forces acting on the lacerating chamber

Forces acting on the wall of lacerating chamber can be vertical or horizontal

$$P_v = \frac{\rho g D}{4\mu K} \left[ 1 - e^{-\frac{4h\mu K}{D}} \right] \tag{Janssen equation} \tag{4}$$

Where  $P_v$  = Vertical stresses at the bottom of the lacerating chamber as shown as Fig. 3

$\rho$  = density of the material to be fed in the lacerating chamber

$g$  = acceleration due to gravity = 9.81m/s<sup>2</sup>

K = Janssen coefficient

D = top diameter of the lacerating chamber

$\mu$  = Coefficient of wall friction,  $\mu = 0.3$

h = height of the lacerating chamber

$$P_H = \mu P_v \tag{Janssen equation} \tag{5}$$

Calculation:

$$P_v = \frac{25 \times 9.81 \times 0.30}{4 \times 0.30 \times 0.33} \left[ 1 - e^{-\frac{4 \times 0.50 \times 0.30 \times 0.33}{0.3}} \right]$$

$$= 89.77 \text{ N/m}^2$$

$$P_H = 0.3 \times 89.77$$

$$= 26.93 \text{ N/m}^2$$

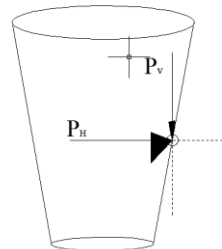

Fig. 3: Stresses analyses of the chamber

Drive Mechanism of Lacerating Machine :

This work would make use of the V-belt and Pulley system because of the following reasons:

- a) It transmit energy better, speed at the driven end can be reduced by increasing the diameter of the driven
- b) Readily available in Nigerian markets
- c) It is cheaper than other means of transmission
- d) Parts involved in this set-up can be replaced and easily repaired.

Pulley

$$\frac{D_1}{D_2} = \frac{N_1}{N_2} \quad (\text{Spolt, 1988}) \quad \dots\dots\dots 6$$

Where  $N_1$  = revolution of driving (electric motor) shaft, in rpm

$N_2$  = revolution of driven (lacerator) shaft, in rpm

$D_1$  = diameter of driver pulley, in mm

$D_2$  = diameter of driven pulley, in mm

$$\frac{D_1}{D_2} = \frac{60}{180}; \quad D_2 = 3D_1$$

Based on available sizes of pulley (Khurmi and Gupta, 2009),  $D_1 = 50\text{mm}$ ,  $D_2 = 150\text{mm}$

Transmission Shaft and Speed

The electric motor to be used will be 2HP with an output speed of 1880 rpm i.e.  $N_1 = 1880\text{rpm}$

$$\frac{N_1}{N_2} = \frac{3}{1}$$

$$N_2 = \frac{1880}{3} = 626.67 \text{ rpm}$$

$$N_1 = 1880\text{rpm} \quad N_2 = 626.67\text{rpm}$$

2.2.3.2 Shaft Diameter

$$d^3 = \frac{16}{\pi\sigma} \sqrt{(K_b M_b)^2 + (K_t M_t)^2} \quad (\text{Hall et al.}) \quad \dots\dots\dots 9$$

Where  $d$  = diameter of the shaft

$\sigma$  = allowable stress ( $\text{Nm}^{-2}$ )

$K_b$  = the combined shock and fatigue failure applied to bending moment

$M_b$  = bending moment (Nm)

$K_t$  = combined shock and fatigue factor applied to torsional moment

$M_t$  = torsional moment (Nm)

$$\text{Bending Stress: } \sigma = \frac{M_b x r}{I} = \frac{32 M_b}{\pi d^3} \quad \dots\dots\dots 10$$

Where  $M_b$  - bending moment

$d$  - Shaft diameter

$$I = \frac{\pi d^4}{64} \text{ For cylindrical shaft}$$

$$\text{Torsional Stress: } \tau = \frac{M_t x r}{J} = \frac{16 M_t}{\pi d^3}$$

Where  $M_t$  - torsional moment

$d$  - Shaft diameter

$$J = \frac{\pi d^4}{32} \text{ For cylindrical shaft}$$

From the list of standard sizes of transmission shaft, as given in Khurmi and Gupta 2009, a diameter size of 25mm was selected. Material is to be steel rod.

V-Belt Analysis

Length of Belt

$$L = 2C + \frac{\pi}{2}(D1 + D2) + \frac{(D2-D1)^2}{4C} \text{ (Khurmi and Gupta, 2009)}$$

Where L = length of the belt

C = centre distance between the larger pulley and the smaller one

D1 = diameter of driver (i.e. smaller pulley)

D2 = diameter of driven (i.e. larger pulley)

$$L = 2 \times 0.28 + \frac{\pi}{2}(0.05 + 0.15) + \frac{(0.15-0.05)^2}{4 \times 0.28} = 0.883\text{m}$$

$$L = 883\text{mm}$$

Belt Contact Angle

$$\sin \alpha = \frac{R2-R1}{C}$$

$$= \frac{75-25}{280} = \frac{50}{280}$$

$$\alpha = 10.2866^\circ = 10.3^\circ$$

Angle of Lap

$$\theta = 180 - 2\alpha$$

$$= 180 - 2(10.3) = 159.4^\circ$$

$$= 159.4 \times \frac{\pi}{180} \text{ rad} = 2.782 \text{ rad}$$

Groove Angle of the pulley

$$2\beta = 34^\circ \quad \beta = 17^\circ$$

Belt Tension

$$\log_e \left( \frac{T1}{T2} \right) = \mu\theta \text{ (Khurmi and Gupta 2009)}$$

$$\frac{T1}{T2} = e^{\mu\theta}$$

Where T1 = Tension in the belt on tight side

T2 = Tension in belt on slack side

Θ = Angle of contact in radians

μ = coefficient of friction between belt and pulley

$$2.30 \log \left( \frac{T1}{T2} \right) = 0.3 \times 2.782$$

$$\frac{T1}{T2} = 2.306 ; \quad T1 = 2.306T2$$

Power Transmitted By Open Belt

$$P = (T1 - T2)V \text{ Where } V = \text{velocity of driving pulley} \text{ (Khurmi and Gupta, 2009)}$$

$$V = \frac{\pi D2 N1}{60} = \frac{\pi \times 0.15 \times 180}{60}$$

$$= 1.414 \text{ m/s}$$

$$2 = (T1 - T2) 1.414$$

$$T1 - T2 = \frac{2}{1.414} = 1.414$$

$$T1 = T2 + 1.414$$

Substitute  $T1 = 2.306T2$  into the equation above

$$2.306T2 - T2 = 1.414$$

$$1.306T2 = 1.414$$

$$T2 = 1.0826 \text{ N} \quad T1 = 2.5 \text{ N}$$

Resultant Torque,  $T_r = (T1 - T2)R$

Where R = radius of bigger pulley

$$= (2.5 - 1.1)0.075$$

$$= 0.105 \text{ Nm}$$

**Table 1: Materials of Construction**

Serial Number	Part	Material of Construction	Quantity	Specification
1	Shaft	Mild steel	1	24mm diameter, 300mm length.
2	Support / Frame	Iron plate, Iron pipe	1	4mm thick plate 500x600mm.
3	Pulley	Mild steel	2	30mm pipe metal. 50mm, 150mm.
4	V- Belt	Rubber	1	12.5mm thick, 410mm length.
5	Bearing	Steel	5	25mm internal diameter.
6	Blade	Steel	1	2mm thickness, 100mm Length.
7	Hopper unit	Iron Sheet	1	2mm thickness.
8	Blade Spikes	Steel	30	2mm thickness, 25mm height.
9	Electric motor		1	2HP, 1880rpm. Single Phase.
10	Electrode		25	
11	Bolt	Mild steel	13	10mm diameter, 8mm diameter
12	Grinding disc	Steel	3	120mm diameter

### Fabrication Processes

The materials used for the fabrication were procured locally and were transported to ISOLTEC where the fabrications were carried out. Fabrication commenced with the construction of the frame. The top of the frame was iron sheet metal 4mm gauge, while the legs were made from iron pipe metal 40mm x 40mm. using the grinding machine, and occasionally hack saw with blade; the parts were cut into sizes as in Plate 1. The dimensions of each part of the frame are shown in Fig. 4. The iron pipes were arranged and welded together. It was welded at right angle to each other so as to allow for rigidity and easy attachment of the frame top. The member of the top was then placed and welded on the frame as shown in Plate 2.



**Plate 1:** Iron Sheet and Electric Sanding



**Plate 2:** Frame/ Support Member

#### Construction of the Shaft

The shaft is made from mild steel 24mm diameter 300mm long. This was turned on a Lathe machine. One end is attached to the blade unit while the other end is connected to the pulley. The drawings of the shaft are shown Fig. 5.

#### Construction of Lacerating chamber

The lacerating chamber was constructed from iron sheet metal 2mm gauge. Sheet used was 943.7mm x 600mm. After cutting to size, the sheet was rolled to form the lacerating chamber shape as shown in the Fig. 6. Plate 3 shows the inside of the lacerating chamber being welded together for rigidity. Four supports were attached to the sides of the lacerating chamber to ensure balance and rigidity. Adequate care was taken during welding. The dimensions of the lacerating chamber are shown in Fig. 7.

#### Construction of Blade Spikes

The spikes were made from steel 5mm diameter by 25mm high. Refer to Plate 4a, 4b and Fig. 8. The spikes were welded to the base of the lacerating chamber to ensure rigidity.

#### Construction of the blade

The blade was made from 2mm gauge spring steel metal. The blade was turned into shape on a vice following the set specifications. See Fig. 9 and 10

#### Assembly of parts

The parts of the machine were assembled together as shown in the exploded drawing in Plate 5 and Fig. 11.

#### Finishing

Finishing involves sanding, grinding and painting of the entire machine as shown in Plate 6

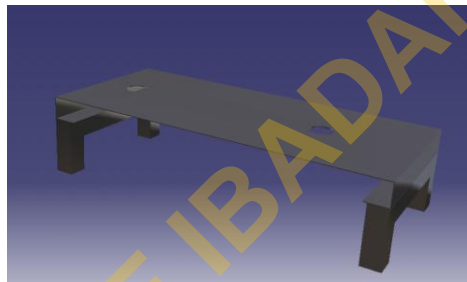

Fig. 4a 3D Representation of the Frame and Support

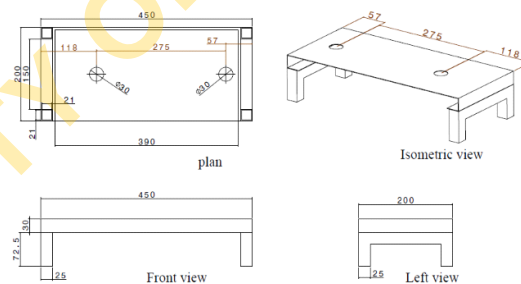

Fig. 4b. 2D Representation of the Frame/Support

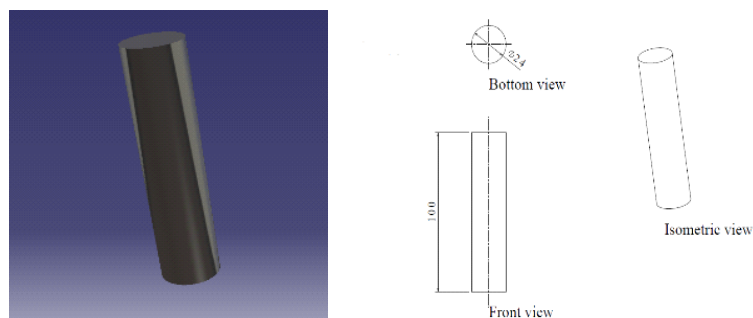

Fig.5. Drawings of the shaft



Fig. 6 3D Drawing and Dimensions of Lacerating chamber

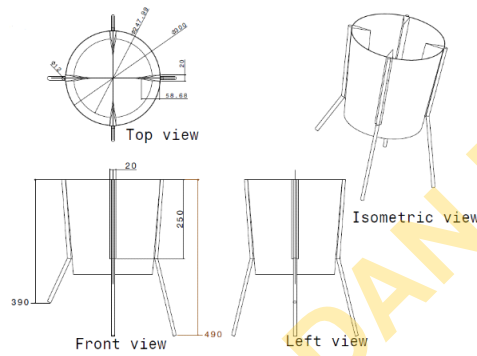

Fig. 7 2D Drawing and Dimensions of Lacerating chamber



Plate 3 Welding the Supports of the Lacerating chamber



Plate 4 Spike unit in the lacerating chamber

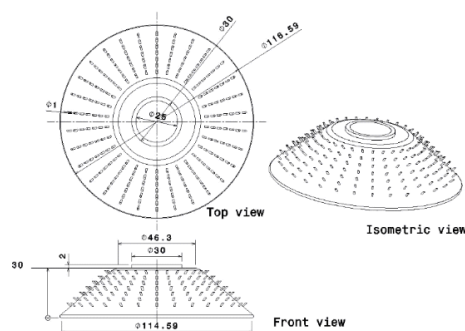

Fig. 8 Blade spike unit drawing

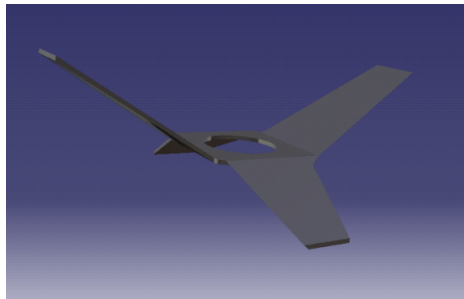

Fig 9. Blade Drawing

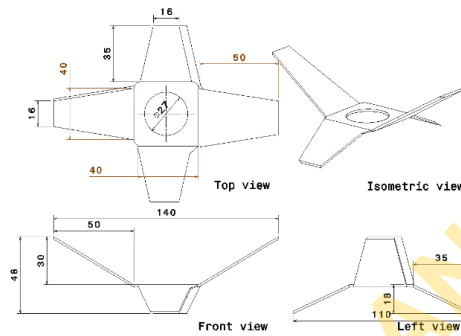

Fig. 10 . 2D Drawing of the Blade

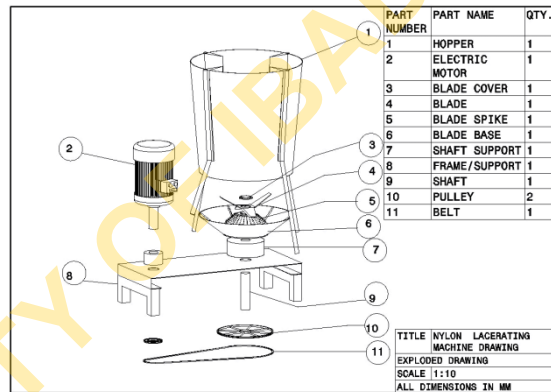

Fig. 11. Exploded view of lacerating machine



Plate 5 Top view of fabricated machine



**Plate 6** The fabricated water sachet lacerating machine

#### Cost of Fabrication

The estimated cost of fabrication of the sachet lacerating machine was ₦45,700 (\$225). The bill of materials is shown in the Table 2. Maintenance practices are necessary to ensure proper working of the machine and to make the machine safe for use.

**Table 2: Bill of Materials**

Serial Number	Part	Price (₦)
1	Shaft	1000
2	Support / Frame	3000
3	Pulley	1800
4	V- Belt	500
5	Bearing	2500
6	Blade	2500
7	Lacerating chamber	2500
8	Blade Spikes	300
9	Electric motor	10000
10	Electrode	2500
11	Bolt	400
12	Grinding disc	1500
13	Paint	700
14	Fabrication and Labour Cost	10500
15	Miscellaneous	6000
<b>TOTAL</b>		<b>₦45,700</b>
@ ₦200=\$1.00		<b>\$225</b>

#### Testing and Performance evaluation of the Lacerating Machine

Disuse water sachets were collected at dump sites around the University of Ibadan Campus. The samples were washed, sorted, weighed and batched. The operational variables considered include the quantity lacerated (100 to 500g), the quality of the output and the time taking to achieve the desired sizes. The samples lacerated were weighed, sorted into sizes and efficiencies were determined. The test results obtained were subjected to descriptive statistics, analysis of variance (ANOVA) and test of significance using Duncan Multiple Range Tests.

### III. Results and Discussion

#### Machine Capacity and Efficiency

The machine capacity and efficiency are shown in Fig 12. The machine capacity was 7.5kg/hr or about 450 pieces of disuse sachets bags were lacerated per hour. The lacerating efficiency was 90.1%. The sawing blade teeth provided tearing, cutting and shearing techniques for the sachets. Also the fixed spikes created a holding device for the blades for easy cutting the sachets.

#### Effect of lacerating time on size reduction

The effect of lacerating time on size reduction was determined and the result showed that the longer the lacerating time the more the size reduction. The desired sizes, 4 to 6mm were obtained at about 4 minutes and at the blade speed of 1880rpm. There was significant difference between the lacerating time and size reduction,

and also between the input mass and lacerating time. However there was no significant difference between water sachets obtained from different locations.

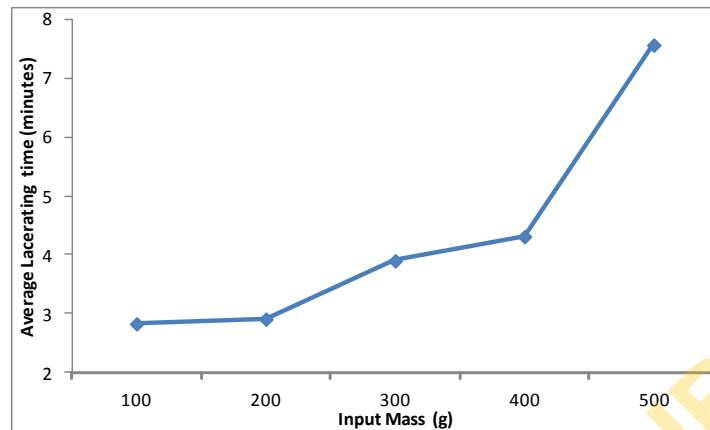

Fig.12 Effect of input mass on average time taken

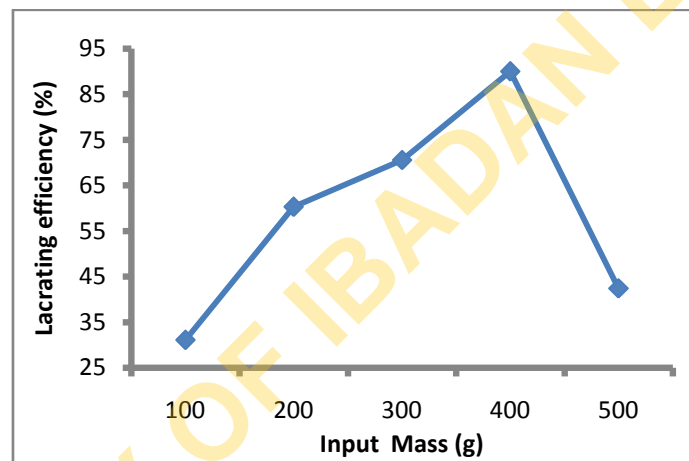

Fig. 13 Effect of input mass on lacerating efficiency

#### IV. CONCLUSION

The machine for lacerating disuse water sachet has been designed and fabricated using locally sourced and available materials. Performance evaluation indicated that it converted an average of 8000 sachets per hour. The blades are rotated by a 2hp electric motor at a speed of 1880rpm. The average machine capacity and lacerating efficiency were 7.5kg/hr and 90.1% respectively at a production cost of \$225. The study shows that disuse water sachet can be prepared and processed as reinforcement in cement composite with enhanced properties.

#### Data Availability

All data, models, and code generated or used during the study appear in the submitted article.

#### REFERENCES

- [1]. Adegoke C.W., Gasu M.B., and Abiona S. (2009). Waste-to-wealth Technology in conversion of pure water nylon waste to an alternative building material product. Proceedings of the First National Conference of the Faculty of Technology, Obafemi Awolowo University, Ile-Ife, Nigeria (Retav 2009), November 17-19, 2009. Vol. I. Pp. 65-68.
- [2]. Bain R., Desrochers C., Ramanathan A. and Stenson J. (2007); Recycling Plastic Water Sachets. D-Lab II: Design. May 16, 2007.
- [3]. Edoga M.O., Onyeji L.I. and Oguntosi O.O. (2008); Achieving Vision 20:2020 Through Waste Produce Candle. Journal of Engineering and Applied Sciences 3(8): Pp. 642-646.
- [4]. Gbasouzor A.I., Ekwuozor S.C., and Owuama K.C. (2013). Design and Characterization of a model polythene Recycling Machine for Economic Development and Pollution Control in Nigeria. *Proceedings of the World Congress on Engineering July 3 - 5, 2013. London, U.K.* Vol. I, ISSN: 2078-0966 (online).
- [5]. Hall H.S., Hollowenko A.R and Laughlin H.G. (1980). Theory and Problems of Machine Design. *Schuam's Outline Series*.
- [6]. Khurmi R. S. and Gupta J. K. (2005): A textbook of machine design. Eurasia Publishing House (PVT) Ltd. Ram Nagar, New Delhi 110066
- [7]. Nithyananth S., Libin S., Nithin M., and Suraj S. (2014). Design of Waste Shredder Machine. *International Journal of Engineering Research and Applications*. ISSN: 2248-9622, Vol. 4, Issue 3. Pp 487-491.

- [8]. Odior A. O. Oyawale F.A., and Odusote J.K. (2012). Development of a polythene recycling machine from locally sourced materials. *Industrial Engineering Letters*.ISSN 2225-0581 (online) Vol 2, No.6, 2012. Pp. 42–46.
- [9]. Odusote J.K, Muritala A.A, and Oyawale F.A. (2012) Design and Fabrication of Polythene/Nylon wastes recycling machine.*Proceedings of CIVIL2012 at UNILORIN 4th Annual and 2nd International Conference of Civil Engineering July 4-6, 2012*. Pp.1-7.
- [10]. Odupute F.U. (2012): Politics of Population, Water Supply and Sanitation in Nigeria. *The Nigerian Observer*, Pp. 16-17, February, 2012.

UNIVERSITY OF IBADAN LIBRARY

Omoniyi, et. al. "Development of a Disuse Water Sachet Lacerating Machine; a Fibre Source for Cement Composite Production." *American Journal of Engineering Research (AJER)*, vol. 9(05), 2020, pp. 147-158.