

## Fuel Energy Potential of Pyrolyzed Municipal Solid Wastes

Oladapo T. Okareh <sup>1</sup>, Samuel O. Adegoke <sup>2</sup>, Richard Richard <sup>1</sup>, Sarah A. Akintola <sup>2</sup>, Adekunle A. Adeleke <sup>3</sup> and Peter P. Ikubanni <sup>3\*</sup>

<sup>1</sup> Department of Environmental Health Sciences, Faculty of Public Health, University of Ibadan, Ibadan, Oyo State, Nigeria

<sup>2</sup> Department of Petroleum Engineering, University of Ibadan, Ibadan Oyo State Nigeria.

<sup>3</sup> Department of Mechanical Engineering, Landmark University, Omu-Aran, Kwara State. Nigeria.

Received October 13, 2020; Accepted December 22, 2020

### Abstract

Municipal wastes have become a menace and the recycling of these wastes has been the focus of many researches. In this study, municipal plastic wastes were converted to energy fuel using pyrolysis using a locally fabricated vacuum pyrolyzer. 6 kg of municipal plastic wastes (PP, PET and PS) were collected, grounded into chips using a knife milling machine and were fed into the pyrolyzer to undergo thermal degradation at a temperature of 500°C with holding time of 4-5 hours. The pyrolyzed oil was collected into a Pyrex condenser unit and subjected to pseudo-distillation at 100°C to obtain the volatile components. The percentage pyrolyzed oil mass yield was calculated using mass balance equation. The liquid fuel was analyzed for its physical properties using ASTM methods, while the chemical properties were characterized using FTIR and GC-MS. The pyrolytic process showed the percentage mass yield of the pyrolyzed oil for the municipal plastic wastes oil, char, and non-condensable gas as 82.0, 16.0 and 2.0%, respectively. The derived energy fuel indicated a cloud point, pour point, density and flash point of -26.0°C, -28.0°C, 0.839 g/cc, and 50.0°C and -28.0°C, -35.0°C, 0.744 g/cc, and 30.0 C for pyrolyzed oil and distillates oil, respectively. The FTIR and GC-MS results of the liquid pyrolyzed oil indicate the presence of aliphatic, alkane, alkene, and aromatic hydrocarbons of carbon number C<sub>9</sub>-C<sub>44</sub> in the energy fuel. Physicochemical characterization of the recovered oil indicated similarities with the conventional fossil fuels. The technology has proven to be effective in solving the environmental problems.

**Keywords:** Waste management; Plastic waste; Energy fuel; Pyrolysis; Vacuum pyrolyzer.

## 1. Introduction

The indispensable nature of plastics in today's world cannot be under estimated. This is seen in the employment and largely application of these products both industrially and domestically. This could be due to their lightweight, durability, energy efficiency, coupled with an increase rate of production, and design flexibility. Several studies have shown that plastic wastes are the third largest compositions of municipal waste streams after organic wastes and paper [1-2]. According to World Bank [3], plastic wastes remain a huge component of municipal solid wastes (MSW), with different disposal methods yet to be achieved, especially in developing countries, such as Nigeria [3]. Plastic waste, in Nigeria, has been estimated to account for about 20% of total wastes [4]. An effective method for disposal of plastic wastes has not yet been implemented to tackle the great environmental hazards posed by waste plastics. Plastics are polymers that slowly biodegrade and also contain mostly carbon-hydrogen, and few other elements like nitrogen. Plastics have been identified to contribute significantly to problems associated with waste management due to their non-biodegradability nature [5]. According to Rapsing *et al.* [6], out of 129 million tons of waste plastics produced yearly all over the world, 77 million tons are produced from petroleum. Over 78 wt.% of total plastic wastes are thermoplastics such as recyclable polyolefin, polyethylene terephthalate (PET),

polypropylene (PP), polystyrene (PS) and polyvinyl chloride (PVC), while the rest are thermosets such as polyurethanes epoxy, which cannot be recycled [7].

Different methods such as incineration (energy recovery), landfill, true material recycling and chemical recovery, have over the years been identified for management of municipal and industrial plastic wastes [7]. However, incineration of waste plastics has been reported to constitute a whole lot of environmental problems incriminating from increased emission of harmful compounds [8-9]. Despite the availability of these methods, there still arose questions on which treatment method is best suitable and sustainable for plastic wastes in waste management with regards to its advantage in environmental, economic, energetic, and political perspectives. Consequently, enormous researches have been carried out with the objectives of converting these wastes into useful products/substances with little or zero environmental implications via recycling (mechanical, chemical and biological) methods [1, 6-11]. On this note, it therefore becomes imperative that plastic wastes be equally converted to other products valuable for energy recovery and feedstock chemicals (pyrolysis) as it becomes desirable to offset the disposal costs of these wastes substantially [12]. Therefore, in comparison, pyrolysis is a better option for plastic wastes management due to their being environmentally friendly than incineration and disposal in landfills. More so, it is pertinent to state that more sustainable methods other than incineration and disposal in landfills be researched and developed. Recycling scenarios using other techniques such as catalyst and biological methods, and or recycling of other fractions (mixed plastics, PS, PP, PET and PVC) performed less favorably than pyrolysis because of the deleterious implications on human and eco toxicity from the land filling of the resulting residue [13].

One of the tertiary recycling methods is pyrolysis. Pyrolysis can either be thermal or catalytic and it represents a futuristic alternative for the conversion of polymers into liquid hydrocarbons and gas [14]. Common plastics such as high-density polyethylene (HDPE), low density polyethylene (LDPE), polypropylene (PP), polystyrene (PS), and polyethylene terephthalate (PET) found in MSW are all potent raw materials for pyrolysis. In this type of recycling, thermal degradation of plastics produces liquid fuels and chemicals with high added value from waste plastic fragments or segregation [6]. PE, PP, and PS, are preferred for the feedstock in the production of liquid hydrocarbons.

Hossain *et al.* [14] designed a fixed bed pyrolysis system using biomass as heating source. The pyrolyzer yielded 51 wt.% at 500°C but Rapsing *et al.* [6] yielded 78.1% for type 6 polystyrene plastic. Also, Patel *et al.* [7] designed a waste plastic pyrolysis reactor and opined that the output of the pyrolyzed oil is dependent on the plastic type. However, in this work, this pyrolyzer is a unique locally fabricated reactor in that, unlike other types of pyrolyzers where there are two openings for material feeding and char collection, its rotatory nature makes it possible for char to be collected through the same opening where samples were fed in, thus enhancing its operational simplicity.

This study aims at operating and testing of a locally fabricated pyrolyzer as an appropriate technology and environmentally benign based solution for reducing plastics in municipal solid waste. The recovered oil obtained from plastic wastes via the pyrolyzer was analyzed to evaluate the physical properties and chemical compositions. The values obtained were compared with the conventional fossil fuels.

## 2. Materials and methods

### 2.1. Pyrolyzer installation

Metal scraps composed mainly of stainless and mild steels were used for the fabrication of the pyrolyzer. The inner part is made of stainless steel (EN 1.4401), which contains chromium to form a passive film of chromium oxide for surface corrosion prevention [15]. 3 mm diameter mild steel was used to cover the outer part for safety purpose based on the recommendation by Adegoke *et al.* [15]. Welding machine was used in joining various parts of the component of the pyrolyzer during the fabrication. Lathe machine has been used for cutting the stainless steel pipes and sheets. Drilling machines were used for operation which required drilling such

as the construction of the flanges and fixing of the handle while grinding machine was used to smoothen the surface of the flanges. The schematics layout of the pyrolyzer is seen as presented in Figure 1a, while Figure 1b shows the whole view of a pyrolyzer with a rig. Figure 2 shows the flow process of the pyrolyzer fabrication and assembly process. A rig made up of mild steel angle bar of 624.0cm x 4.0cm dimension supported by four pillars was constructed and the pyrolyzer tube was placed on the rig (Figure 1b). The 500 W circular body heater and two 2000 W spiral body heater were winded and tacked from the base to the upper body of the main pyrolyzer chamber (made of steel). A K-type thermocouple, which measures up to 1000°C was incorporated into the chamber for temperature reading and regulation. Fiber glass insulators of bulk volume 103717.33 cm<sup>3</sup> were placed around the inner main reactor tube. This was to prevent heat escape to the environment and as well ensure heat localization to the feed materials. Mild steel with dimension 85.0cm y40. 0cm was placed round the insulator. Finally, a dismantable outer body cover made of mild steel with dimension 155.5 cm x68.0 cm were joined together with bolt and nut around the insulator and a bottom body cover made of steel with dimension 24.5 cm was welded to the pyrolyzer to serve as a base.

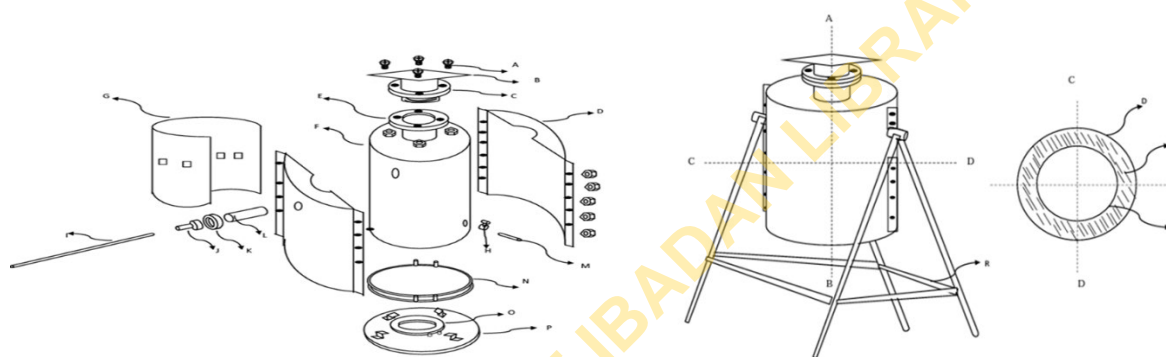

Fig. 1a. Schematics layout of the pyrolyzer

Fig.1b. Whole view of a pyrolyzer with a rig

**Keys**

- |                            |                         |                                |
|----------------------------|-------------------------|--------------------------------|
| A- Bolt                    | G- Heating element wrap | M- Lower inlet                 |
| B- Top screw lock          | H- Locking valve        | N- 2000W Body spiral heater    |
| C- Top screw lock flange   | I-Outlet tube           | O- 500W Bottom circular heater |
| D- Outer body cover        | J- Reducer tube         | P- Bottom cover plate          |
| E- Lower screw lock flange | K-Connector             | Q- Fabre glass insulator       |
| F- Main reactor tube       | L- Main outlet tube     |                                |

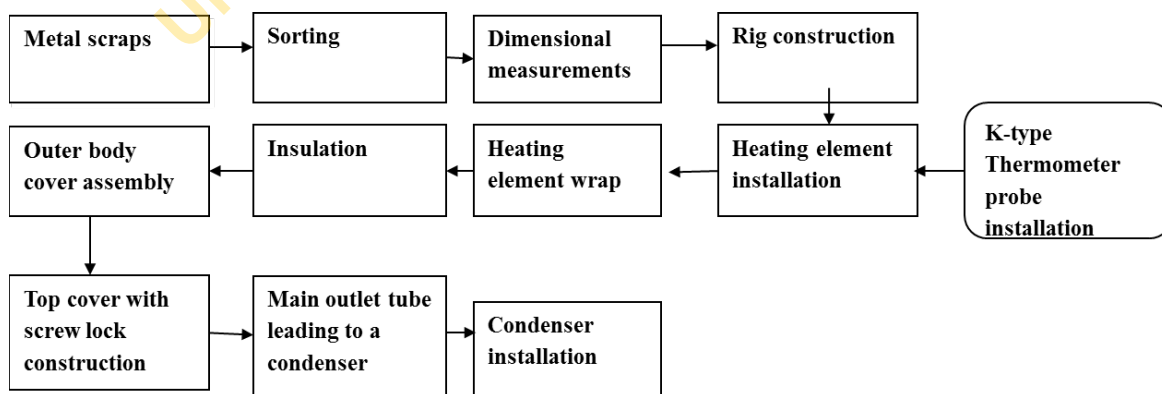

Fig. 2. Flow process of the pyrolyzer fabrication and assembly process

Also, a steel top screw lock of 0.45cmx1.10cm and mild steel top screw lock flange of 18.9 cmx0.10cm were carefully welded to ensure an effective bolt and nut system. This is to ensure that, the chamber is well locked during pyrolysis to avoid product loss and oxygen influx. A part made up of outlet tube ( $\Phi=1.25\text{ cm} \times 82.5\text{ cm}$ ), (reducer tube (mouth,  $\Phi = 1.25\text{ cm}$ , base  $\phi = 6.0\text{ cm}$ ), connector ( $\Phi = 6.0\text{ cm}$ ) and the main outlet tube ( $\Phi = 5\text{ cm}$ ) all made up of steel metal was produced from the main reactor tube in such a reduced diameter to initiate the gas compression process into oil before leading the uncompressed gas into a condenser for conversion of condensable gases into liquid while the incondensable gases may be collected for further usage [15].

## 2.2. Condenser installation

The chamber was incorporated with a Pyrex condenser for oil collection. The condenser has two chambers (inner and outer). The inner chamber collects the vapour-liquid products while the non-condensable gas was flared. The outer chamber provides the cooling environment for the product condensation because it has both inlet and outlet where the cold water filled with ice pack entering in and out of the condenser, thus keeping the condenser at a steady cold temperature for condensation to occur. The liquid product was collected with a bottle; thus, making it a complete pyrolysis chamber and ready for use.

## 2.3. Sample collection and preparation

Municipal plastic wastes were collected from municipal wastes stream in Ibadan metropolis and its environs. Waste collection bag was used at different 5 collection points after which the samples were sundried at approximately  $35^\circ\text{C}$  for 5 hr/day for one week and grinded into small diameter chips of about 2-4 mm using a knife milling machine.

## 2.4. Analysis of the samples

Ultimate and proximate analysis of the samples were carried out at the Department of Agronomy Laboratory, University of Ibadan, Ibadan following the recommendation by Sarker *et al.* [5]. The sample was later weighed using a weighing balance (Serial no: 1119401867, PB3002-s model) to obtain the required quantities before the conversion process was to be carried out.

## 2.5. Pyrolysis procedure

About 2 kg each of the plastic chips types (PP, PE, PS) were fed into the pyrolyzer. The top cover of the pyrolyzer, where the samples were fed through, was equally tightened with knots and cellulose lag was used to line the lid for the purpose of preventing heat escape. The electrical switch was turned on to supply power to the vacuum pyrolyzer. The temperature regulator was adjusted to the reaction temperature of  $500^\circ\text{C}$ , with the holding time of up to 4 hrs.

A Graham condenser made of Pyrex material was clamped to a stand and connected to a pipe installed to the pyrolyzer to capture the vapour/liquid product. The condenser has chilled water flowing in and out of the condenser for proper heat exchange. The condenser collected the vapour turned liquid product into a bottle. The liquid oil obtained was subjected to semi distillation at  $100^\circ\text{C}$  to obtain the volatile components of the oil. Non condensable gases were allowed to go into the air while the plastic black bio-char was collected from the pyrolyzer by exploring the rotatory potential of the pyrolyzer that enables the char collection from the

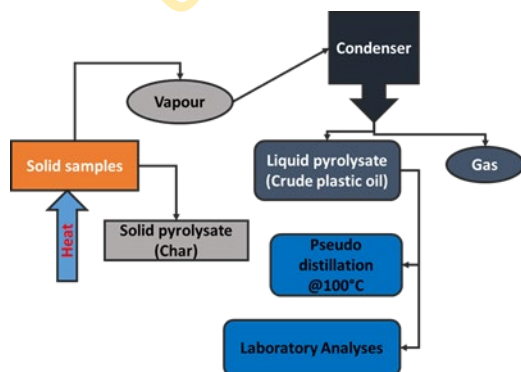

Fig. 3. Full experimental flow diagram

same point of material feeding. Figure 3 gives the full experimental flow diagram.

## 2.6. Mass balance of pyrolyzed mass yield

The liquid and char yield percentages were obtained using Equations (1) and (2) respectively, while the non-condensable gas yield was calculated using Equation (3).

$$\% \text{ Liquid oil} = \frac{WtL}{OWtS} * 100 \quad (1)$$

$$\% \text{ Char} = \frac{WtC}{OWtS} * 100 \quad (2)$$

$$\% \text{ Gas} = 100 - (\% \text{ Liquid} + \% \text{ Char}) \quad (3)$$

where WtL= weight of liquid; WtC=weight of char; OWtS=original weight of samples.

## 2.7. Physico-chemical characterization of the recovered distillate energy fuel

The density of the oil was done using a pycnometer based on the recommendation by Khan *et al.* [16]. The pour point and the cloud point were conducted by pouring the sample oil to be measured inside the test jar. The test jar is thereafter placed inside an already methanol loaded test bath. Methanol is used as the cooling solvent. The cryostat machine (Model no: 94100-3V, Serial no: 1017543) was put on and monitored till when the oil becomes cloudy (the temperature is noted). The oil is taken out of the test bath after freezing and then allowed to pour by inverting the test jar. Pour point is the temperature at which the oil begins to pour. The pour and cloud points were done based on the recommendation of Akhil *et al.* [17]. The flash point was carried out according to ASTM D93 [18]. Seta Flash machine (Series 3, Model: 30000-0 U/Serial No: 1019937) was loaded with the sample oil using a syringe while the gas supply was on. The flash point was taken at a point which when the shutter is opened; it gives a pop sound and the second line showed flash. Chemical analysis characterized with Fourier transform infrared (FTIR) spectroscopy (Perkin Elmer 1725x) to check for the presence of hydrocarbon functional groups and gas-chromatography mass spectrometry (GCMS) (Avio 200 ICP-OES) using Perkin Meyer guidelines for the identification of the different hydrocarbon constituents in the energy fuel. The energy values was calculated using the Einstein formula, Equation (4).

$$E = h * v \quad (4)$$

where: h=Planks Constant ( $h = 6.626 \times 10^{-34} \text{ J}$ ); v= Frequency in Hertz ( $\text{sec}^{-1}$ );  $V=C/\lambda$   
C=Speed of light  $C = 3 \times 10^{10} \text{ m/s}$ ;  $W=1/\lambda$  (where  $\lambda$  = wave length)  $W =$  wave number in  $\text{cm}^{-1}$ .

## 3. Result and discussions

### 3.1. Fabricated vacuum pyrolyzer

A pyrolysis chamber was designed and fabricated with the use of local materials. The pyrolyzer is a vacuum pyrolyzer, which has both mechanical and electrical features that works on the principle of converting electrical energy to heat energy. This aids in the thermal degradation of plastic polymeric products. The output pyrolyzed percentage mass yields for oil, gas, and char obtained from the use of the chamber showed its effectiveness and suitability as a pyrolytic recovery chamber. The chamber with the volume of 28 298.8  $\text{cm}^3$  was able to contain 6 kg weight of sample for a single run and was able to recover 4.86 kg and 0.98 kg of pyrolyzed oil and bio-char, respectively. This pyrolyzer is a unique locally fabricated reactor in that, unlike other types of pyrolyzer by Adegoke *et al.* [15], Patel *et al.* [7], Jasan cross *et al.* [8], Abdul Aziz *et al.* [14], Hossain *et al.* [19] where there are two openings for material feeding and char collection. Its rotatory nature makes it possible for char to be collected through the same opening where samples were fed in, thus enhancing its operational simplicity. However, one singular similarity about these pyrolyser reactors must be such as the ability to pyrolyse in the absence of oxygen.

### 3.2. Product yields

Figure 4 shows the oil, char, and distillate obtained from the pyrolysis experiment. The mixed plastic wastes bio-oil recorded was 4.92 kg amounting to 82% fuel oil yield as seen in Figure 5. This is close to that obtained in a similar study done by [5]. The high oil yield in

plastic mixture is due to radical formation during polystyrene decomposition thus, enhancing more oil production [20-21]. Therefore, the conversion of polyethylene and polypropylene can be improved by the addition of polystyrene [22]. The high mass yield from mixed plastic also confirms the assertion by Al-Salem *et al.* [23] and Achilias, *et al.* [24] that pyrolytic process offers the advantage of working with mixed and contaminated plastics. The char weight was 0.96 kg, which amounts to 16 % of the total mixed plastic wastes, as shown in Figure 5.



Fig. 4. (a) Oil (b) Char (c) Distillate

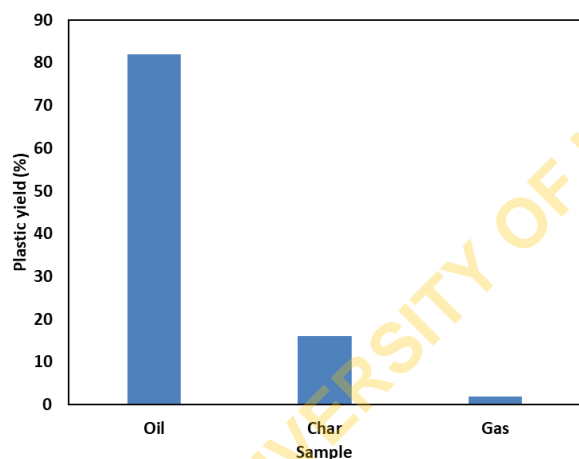

The dark color is as a result of the high presence of carbon (81.20), as shown in the ultimate analysis presented in Table 1. This is in consonance with study recorded by Adegoke *et al.* [15]. The only way to calculate the amount of non-condensable gas flared is by using mass balance equation (Equation 3), which gives 0.12 kg of the total mixed plastic waste. More studies can be done to capture and know the compositions of gas recovered from plastic pyrolysis.

Fig. 5. Percentage products yield

Table 1. Proximate and ultimate analysis of mixed wastes

Property	Mixed plastics
Proximate analysis (wt. %)	
Moisture content	0.50
Volatile matter	95.19
Fixed carbon	1.15
Ash content	3.16
Ultimate analysis (wt. %)	
Carbon (C)	81.20
Hydrogen (H)	13.3
Nitrogen (N)	0.44
Sulphur (S)	0.36
Oxygen (O)	3.83
Chlorine (Cl)	0.87

### 3.3. Physicochemical properties of the oil yield

Table 2 gives the mean results and standard deviation of some of the physical properties of the recovered mixed plastic waste oil and its distillates giving the cloud points of -24 and 28°C, respectively. This is close to what was reported by Akhil *et al.* [17] for conventional fuels; Kerosene (-21.9°C) and diesel plus kerosene (-25.3°C). Although, the result is not in line with a similar study carried out by Sarkar *et al.* [5] on the method of converting municipal proportional waste plastics into liquid hydrocarbon fuel using activated carbon which recorded 10.9°C). The variation can be attributed to the use of activated carbon as a catalyst in the study. The pour point which is the temperature at which the oil loses its flow characteristics is used to determine how suitable an oil sample is for a low temperature installation.

Table 2. Physical properties of plastic waste fuel oil

Properties	Municipal plastic waste oil	Distilled oil
Cloud point (°C)	-24.00 ±2.64	28°C
Pour point (°C)	-28.00±3.46	<-35°C
Density (g/cc)	0.833 ±2.64	0.749
Flash point (°C)	50.00	30.00 ±2.64
Appearance	Dark brown	Light yellow

In this study, the results of the oil samples were relatively low as shown in Table 2. This corroborates the work of Khan *et al.* [16] that recorded <-15°C for waste plastic pyrolysis oil (WWPO). Therefore, the reported pour point for the mixed plastic fuel oil sample indicates its suitability in hot temperate regions and as against a low temperate region [16]. The densities from mixed plastic oil was 0.839 g/cc while the distillate was 0.749 g/cc. These fall within the same range of conventional fuels such as kerosene (0.82 g/cc), diesel (0.844 g/cc), furnace fuel (0.92 g/cc), light fuel oil (0.9101 g/cc), and waste plastic pyrolysis oil (0.7477 g/cc) [16]. To avoid the damage of engine, the flash point of a fuel oil should not be as low as -15°C [16]. From the results obtained with different municipal waste plastic oils, the densities are approximately in the same range with different conventional fuels; hence municipal waste plastic fuel oils can be used in place of the conventional fossil fuel.

Flash point, which is the lowest temperature taken for a fuel to vaporize or lost to air with ignition potentials, is used to determine fire hazard associated with fuels. The flash point of 30 and 50°C was recorded for mixed plastic waste distillate and liquid pyrolyzed oil, respectively. 30°C is quite low. This is an indication of the presence of a highly volatile compound in the fuel with serious safety implications [16]. Similarly, low flash point of 15°C was reported by Khan *et al.* [16] for waste plastic pyrolysis oil (WPPO) when compared with flash point of furnace oil (66.0°C), diesel (58.5°C), and kerosene (51.0°C). Although the flash point for the mixed plastic sample oil is low, however, it can still be improved by further removal of the lighter components through simple fractional distillation. The spontaneous burning of the liquid fuel as observed is an indication that the liquid fuel is flammable just like the conventional fuels. This agrees with the obtained flash point values and is consistent with the United Nations globally harmonized system of classification and labeling of chemicals, which defines the flash point temperature of flammable liquid between -18.0 to 60.0°C). The distillate showed a light yellowish colour while the crude oil was blackish in colour. This is because of the micro carbons and heavier compositions that account for the blackish colour in the crude pyrolyzed oil must have been distilled off and only retains the lighter ends in the oil [15].

### 3.4. FTIR and GCMS

The result of FTIR analysis of mixed plastic waste fuel is shown in Figure 6 according to their wave numbers and spectra band indicating their corresponding functional groups. The results of GC-MS analysis of fuel from mixed plastic waste oil show different compositions of hydrocarbon compounds, and carboxyl derivative compounds presence in mixed plastic waste fuel oil on the analysis result index in accordance with various retention time given (Figure 7). The FTIR assignment of the mixed plastic waste oil (Table 3) revealed the presence of different

hydrocarbon functional groups. Table 4 reveals various compounds present in the mixed plastic waste. The FTIR and GCMS analysis of mixed plastic wastes polyethylene (HDPE & LDPE), polystyrene and polypropylene showed liquid distribution of majorly paraffin, and aromatic compounds. This corroborates similar work on mixture of low-density polyethylene, polypropylene and polystyrene by Sarkar *et al.* [5]. The benzene styrene and naphthalene found in mixed plastic liquid distribution are due to the presence of polystyrene, which is made up of benzene. Increase in polystyrene or polypropylene content of a mixed plastic wastes greatly enhance the yield of aromatic and alkenic products, thus improving its octane value [6].

Table 3. FTIR assignments of mixed plastics waste fuel oil.

Wave number (cm <sup>3</sup> )	Type of vibration	Nature of functional group	Energy value(J)
3030.41	=C-H Stretch	Alkene	6.02 x10 <sup>-20</sup>
2926.38	C-H Stretch	Alkane	5.81 x10 <sup>-20</sup>
2864.83	C-H Stretch	Alkane	5.69 x10 <sup>-20</sup>
1699.11	C=C	Alkene	3.37 x10 <sup>-20</sup>
1627.00	C=C	Alkene	3.23 x10 <sup>-20</sup>
1452.43	-CH <sub>3</sub> bending	Alkane	2.88 x10 <sup>-20</sup>
1379.0	-CH <sub>3</sub> bending	Alkane	2.74 x10 <sup>-20</sup>

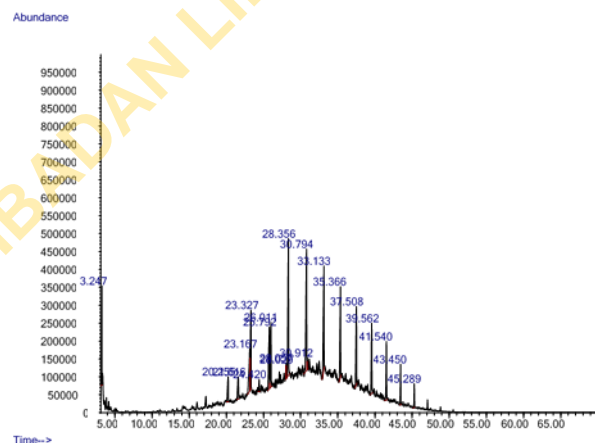
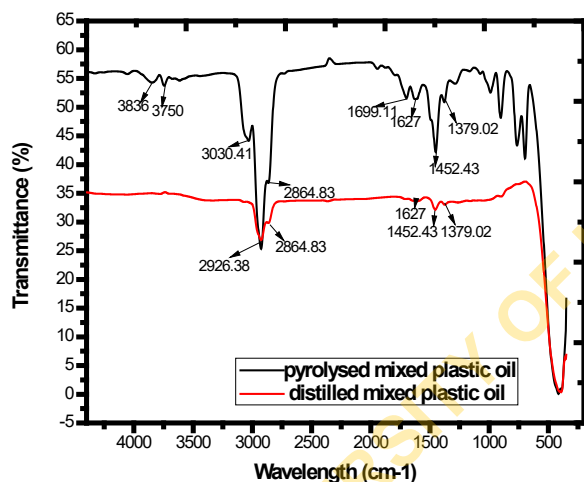

Fig. 6. FTIR spectrum for mixed plastics waste fuel oil and distilled oil

Fig. 7. GC-MS of mixed plastics waste fuel oil

Table 4. GC-MS analysis of waste mixed plastics fuel oil

Peak no	Retention time	Area %	Compounds	Formula
1	3.247	8.29	Alpha-methylstyrene	C <sub>9</sub> H <sub>10</sub>
2	20.253	2.56	Hexadecane	C <sub>16</sub> H <sub>34</sub>
			Decane, 2-methyl-	C <sub>11</sub> H <sub>24</sub>
			Tetradecane	C <sub>14</sub> H <sub>30</sub>
3	21.615	2.54	<b>Pentadecane, 2,6,10-trimethyl-</b>	C <sub>18</sub> H <sub>38</sub>
			Heptane, 2,6-dimethyl-	C <sub>9</sub> H <sub>20</sub>
4	23.165	5.69	<b>Methoxyacetic acid, 2-tetradecyl ester</b>	C <sub>17</sub> H <sub>34</sub> O <sub>3</sub>
			Heptadecane	C <sub>17</sub> H <sub>36</sub>
			Decane, 2-methyl-	C <sub>11</sub> H <sub>24</sub>
5	23.325	7.28	<b>Decane, 2-methyl-</b>	C <sub>11</sub> H <sub>24</sub>
			Hexadecane, 2,6,11,15-tetramethyl	C <sub>20</sub> H <sub>42</sub>
			Undecane, 6-ethyl	C <sub>12</sub> H <sub>26</sub>
6	24.418	0.86	<b>D,L-3-Camphorcarboxylic acid</b>	C <sub>11</sub> H <sub>16</sub> O <sub>3</sub>
			n-Tetracosanol-1	C <sub>24</sub> H <sub>50</sub> O
			trans-2-Undecen-1-ol	C <sub>11</sub> H <sub>22</sub> O
7	25.792	6.39	<b>Octadecane</b>	C <sub>18</sub> H <sub>38</sub>

Peak no	Retention time	Area %	Compounds	Formula
			Pentadecane	C <sub>15</sub> H <sub>32</sub>
8	26.009	5.81	<b>Dodecane, 2,6,11-trimethyl</b>	C <sub>15</sub> H <sub>32</sub>
			Tetratetracontane	C <sub>44</sub> H <sub>90</sub>
			Heptacosane	C <sub>27</sub> H <sub>56</sub>
9	28.029	0.55	Dodecane, 2,6,10-trimethyl-	C <sub>15</sub> H <sub>32</sub>
			7-Oxabicyclo[4.1.0]heptane, 1,5-di methyl	C <sub>12</sub> H <sub>18</sub> O <sub>2</sub>
			Hexadecane	C <sub>16</sub> H <sub>34</sub>
10	28.058	0.94	<b>Hexadecane</b>	C <sub>16</sub> H <sub>34</sub>
			Hexadecane, 7,9-dimethyl	C <sub>18</sub> H <sub>38</sub>
11	28.355	11.21	<b>Nonadecane</b>	C <sub>19</sub> H <sub>40</sub>
			Pentadecane	C <sub>15</sub> H <sub>32</sub>
12	30.793	11.55	<b>Eicosane</b>	C <sub>20</sub> H <sub>40</sub>
13	30.913	0.76	<b>E-8-Methyl-9-tetradecen-1-ol acetate</b>	C <sub>17</sub> H <sub>32</sub> O <sub>2</sub>
			E-11-Methyl-12-tetradecen-1-ol acetate	C <sub>17</sub> H <sub>32</sub> O <sub>2</sub>
			Hexadecenoic acid, Z-11-	C <sub>16</sub> H <sub>30</sub> O <sub>2</sub>
14	33.133	9.22	<b>Heneicosane</b>	C <sub>21</sub> H <sub>44</sub>
			Nonadecane	C <sub>19</sub> H <sub>40</sub>
15	35.364	7.32	<b>Docosane</b>	C <sub>22</sub> H <sub>46</sub>
			Nonadecane	C <sub>19</sub> H <sub>40</sub>
16	37.510	6.01	<b>Tricosane</b>	C <sub>23</sub> H <sub>48</sub>
17	39.564	5.22	<b>Tetracosane</b>	C <sub>24</sub> H <sub>50</sub>
18	41.538	4.17	<b>Pentacosane</b>	C <sub>25</sub> H <sub>52</sub>
			Hexacosane	C <sub>26</sub> H <sub>54</sub>
			Octacosane	C <sub>28</sub> H <sub>58</sub>
19	43.450	2.37	<b>Hexacosane</b>	C <sub>26</sub> H <sub>54</sub>
			Octadecane, 2-methyl-	C <sub>19</sub> H <sub>40</sub>
20	45.286	1.28	<b>Heptacosane</b>	C <sub>27</sub> H <sub>56</sub>
			Sulfurous acid, butyl tridecylester	C <sub>18</sub> H <sub>38</sub> O <sub>3</sub>
			Tetratetracontane	C <sub>44</sub> H <sub>90</sub>

Other compounds found in one or more of the liquid fuels include oxygenated compounds (this may be due to presence of impurities attached to the plastic before pyrolysis process), alcohols, amine, acetate, esters, ethers, carboxylic acids among others. The presence of oxygenated compound is due to the steam produced in the reactor chamber and the process execution in the presence of little air [5], since no nitrogen gas was used to get rid of residual oxygen from the chamber. The presence of other compounds is due to the additives used during plastic manufacturing to obtain the desired products. These additives also serve as catalysts, which aid in the conversion of plastic wastes to energy fuel [5]. The distinctly loss of some bands from the distillates oil shows heavier composition in the oil has been distilled off, thus remaining the lighter components such as bands at 2926, 2864, 1627-1452/cm<sup>-1</sup>, which constitute alkane functional groups (Figure 6).

#### 4. Conclusion

A pyrolyzer has been developed in this study to investigate the energy fuel production potentials of plastic wastes; plastic mixture (PE, PP, and PS), through a thermal pyrolytic recovery process as a way of managing municipal plastic wastes and at the same time recover a resource from it. The pyrolyser was done with strict adherence to the specifications and dimensions contained in the design layout of the different pyrolyzer components. Mixed plastic waste recorded a high percentage yield of 82% bio-oil. Physicochemical characterization of the recovered oil indicated similarities with the conventional fossil fuels. The technology has proven to be appropriate and effective as it could solve the environmental and public health problems associated with indiscriminate plastic waste disposal and to an extent solve the problem of fossil fuel dependency from the local to global community.

## Acknowledgments

The authors would like to say a big thank you to PTFD for her immense contribution to the success of this study.

## References

- [1] Mbue IN, Bitondo D, Azibo BR. Municipal solid waste generation, composition, and management in the Douala municipality, Cameroon. *J. Environ. Waste Manage.* 2015; 2: 91-101.
- [2] Babatunde BB, Vincent-Akpu IF, Woke GN, Atarhinyo E, Aharanwa UC. Comparative analysis of municipal solid waste (MSW) composition in three local government areas in Rivers State, Nigeria *Afr. J. Environ. Sci. Technology*, 2013; 7: 874-881
- [3] Hoorweg D, Bhada-Tata P. What a Waste: A Global Review of Solid Waste Management. Urban development series; knowledge papers no. 15. World Bank, Washington, DC. © World Bank 2012. <https://openknowledge.worldbank.org/handle/10986/17388> (2012). Accessed 14 April 2020.
- [4] OECD environmental policy papers no 12. Improving plastic management: trends, policy responses, and the role of international co-operation and trade. <https://www.oecd.org/environment/waste/policy-highlights-improving-plasticsmanagement.pdf> (2018). Accessed 27 April 2020.
- [5] Sarker M, Rashid M, Rahman MS, Molla M. Production of valuable heavy hydrocarbon fuel oil by thermal degradation process of post-consumer municipal polystyrene (PS) waste plastic in steel reactor. *J. Sustain. Development*, 2012; 2: 89-95.
- [6] Rapsing EC. Design and fabrication of waste plastic oil converter. *Int. J. Interdiscip. Res. Innovation*, 2016; 4: 69-77.
- [7] Patel D P, Patel P S. Design and analysis of waste plastic pyrolysis reactor. *Int. Res. J. Eng. Technology* 2019; 6: 679-687.
- [8] Cross J, Kumar P, Rajan P, Ali J, Joshua C. Design and fabrication of extraction of fuel from waste plastic using pyrolysis. *Int. J. Adv. Res. Innov. Ideas Education*, 2018; 4: 1795-1799.
- [9] Abbas-Abadi M, Haghighi M, Yeganeh H. The effect of temperature, catalyst, different carrier gases and stirrer on the produced transportation hydrocarbons of LLDPE degradation in a stirred reactor. *J. Anal. Appl. Pyrolysis*, 2012; 95: 198-204.
- [10] Adekunle AS, Adeleke AA, Sam-Obu CV, Ikubanni PP, Ibitoye SE, Azeez TM. Recycling of plastics with compatibilizer as raw materials for the production of automobile bumper. *Cogent Engineering*, 2020; 7: 1-14.
- [11] Ohijeagbon IO, Adeleke AA, Mustapha VT, Olorunmaiye JA, Okokpujie IP, Ikubanni PP. Development and characterization of wood-polypropylene plastic-cement composite board. *Case Stud. Construct. Material*, 2020; 13: 1-8.
- [12] Shah S, Khan ZM, Raja IA, Mahmood Q, Bhatti ZA. Low temperature conversion of plastic waste into light hydrocarbons. *J. Hazardous Material*, 2010; 179: 15-20.
- [13] WRAP, Environmental benefits of recycling – 2010 update. [https://www.wrap.org.uk/sites/files/wrap/Environmental\\_benefits\\_of\\_recycling\\_2010\\_update.3b174d59.8816.pdf](https://www.wrap.org.uk/sites/files/wrap/Environmental_benefits_of_recycling_2010_update.3b174d59.8816.pdf) (2010). Accessed 27 April 2020
- [14] Hossain A, Hasan R, Islam R. Design, fabrication and performance study of a biomass solid waste pyrolysis system for alternative liquid fuel production. *Global J. Res. Eng.* 2014; 14: 25-34.
- [15] Adegoke S, Adeleke A, Ikubanni P, Falode O, Alawode A, Agboola O, Adediran A. Design and Fabrication of an ablative pyrolyser for the production of bio-lubricants and chemicals in oil well drilling application. In: International Conference on Energy and Sustainable Environment 20202008, June 28-30, 2020 (In press).
- [16] Khan MZ, Sultana M, Al-Mamun MR, Hasan MR. Pyrolytic waste plastic oil and its diesel blend: fuel characterization. *J. Environ. Public Health* 2016; 2016: 1-6.
- [17] Akhil AG, Mohammed PK, Akhilesh S, Muhammad AC, Khan S. Determination of cloud and pour point of various petroleum products. *Int. Ref. J. Eng. Sci.* 2017; 6: 1-4.
- [18] ASTM D93: Standard Test Methods for Flash Point by Pensky-Martens Closed Cup Tester, ASTM International, West Conshohocken, PA, [www.astm.org](http://www.astm.org), 2019 .
- [19] Abdul Aziz M, Al-Khulaidi RA, Rashid MM, Islam MR, Rashid MA. Design and fabrication of a fixed-bed batch type pyrolysis reactor for pilot scale pyrolytic oil production in Bangladesh. *IOP Conf. Series: Mat. Sci. Eng.* 2017; 84.

- [20] Panda AK, Singh RK, Mishra DK. Thermolysis of waste plastics to liquid fuel. A suitable method for plastic waste management and manufacture of value-added products—A world prospective. *Renew. Sustain. Energ. Rev.* 2010; 14: 233-248.
- [21] Scheirs J, Kaminsky W. Feedstock recycling of waste plastics. John Wiley & Sons, Ltd., 2006.
- [22] Kim JR, Yoon JH, Park DW. Catalytic recycling of the mixture of polypropylene and polystyrene. *Polym. Degradat. Stab.* 2002; 76: 61–67.
- [23] Al-Salem SM, Lettieri P, Baeyens J. Recycling and recovery routes of plastic solid waste (PSW): A review. *Waste Management*, 2009; 29: 625-643.
- [24] Achilias S, Ioannis A, Nikos N, Tsagkalias I, Lefteris A, Dimitra A, Panoraia S, Georgia T. Recent advances in the chemical recycling of polymers (PP, PS, HDPE, PVC, PC, Nylon, PMMA). *Material recycling- Trends and perspectives, In-Tech Open*, 2009: 1-63.

---

*To whom correspondence should be addressed: Peter P. Ikubanni, Department of Mechanical Engineering, Landmark University, Omu-Aran, Kwara State. Nigeria, E-mail: [ikubanni.peter@lmu.edu.ng](mailto:ikubanni.peter@lmu.edu.ng)*

UNIVERSITY OF IBADAN LIBRARY