

**DEVELOPMENT OF A REAL-TIME PETROLEUM PRODUCTS
ADULTERATION DETECTOR FOR LIQUID AND PARTICULATE
CONTAMINANTS**

BY

Olabisi Oluseyi OLOTU

MATRIC No: 136046

B. Tech. Chem Eng. (LAUTECH), MSc, MPhil. Petr. Eng. (Ibadan)

**A Thesis in the Department of Petroleum Engineering submitted to the Faculty of
Technology in Partial fulfilment of the requirements for the Degree of**

DOCTOR OF PHILOSOPHY

of the

UNIVERSITY OF IBADAN

5 DECEMBER 2022

CERTIFICATION

I certify that this thesis was carried out by **OLOTU, Olabisi Oluseyi** with Matric Number **136046** in the Department of Petroleum Engineering, Faculty of Technology, University of Ibadan, Nigeria.

.....

Supervisor
S. O. Isehunwa
B.Sc., M.Sc., Ph.D. (Ibadan)
Professor, Department of Petroleum Engineering
University of Ibadan, Nigeria

DEDICATION

This dissertation is dedicated to God Almighty through our lord Jesus Christ, the author and finisher of my faith, my Alpha and Omega. I also dedicate this to my lovely husband, David. Special Dedication also goes to My Late Dad Chief Isaac Ayodele Olusanya.

UNIVERSITY OF IBADAN LIBRARY

ACKNOWLEDGEMENTS

I appreciate my supervisor, for providing me the opportunity to work on a scientifically interesting and challenging project. My sincere gratitude for his help and guidance throughout this project. Special and countless appreciation goes to Professor G.N Elemo, Engr. Dr. W.B Asiru, Engr S.K Adeyemi, Engr O.O Aremu ,Dr. Akinsete, Dr. Mrs. Akintola, Dr A.J Alawode, Dr Akinpelu to mention and others, for their support. Special thanks to my colleagues at FIIRO, Mr. Williams, Solomon, Kinsley for their close collaboration. I greatly appreciate the help of Mrs. Nike Oloyede, Mrs Florence Olotu, Mrs Esther Osunro, Mr Alalade Ayomide and others who made this work a very interesting one and provided me with assistance.

Appreciation goes to my Parents, Chief and Chief Mrs Olusanya, you are the best parents in the world. You gave me the foundation, and have never stopped your words of encouragement. To my siblings, Dr Mrs Adebambo, Dr Mrs Ijaopo, and Bar. Mrs Yemi Akinola, It is my joy to be part of you. To the love of my life, David and our wonderful children, I appreciate your patience.

Finally, I express my recognition to the entire staff of the Department of Petroleum Engineering, University of Ibadan.

ABSTRACT

Adulteration of petroleum products with the resultant safety, health, environmental and economic impact on the end-users is a challenge in Nigeria and many developing countries. The current commonly used techniques by regulatory agencies and some end-users for quality assurance of the petroleum products are time-consuming and expensive. The development and use of real-time adulterated petroleum products detector in Nigeria will therefore alleviate these problems. This study was therefore designed to develop a device for real-time detection of petroleum products adulterated with liquid and particulate contaminants.

Pure samples of Premium Motor Spirit (PMS), Automotive Gas oil (AGO) and Dual Purpose Kerosene (DPK) were collected from some major petroleum products marketers. Samples of distilled water, naphtha, commercial ethanol, pure and used commercial lubricating oil, and High Pour Fuel Oil (HPFO) were also obtained and used as liquid contaminants; while sawdust, ash and fine-grain sand were used as solid particulates. At temperatures 23:1:28°C, binary mixtures of the products mixed with liquid contaminants were prepared (100:0, 95:5, 85:15, 75:25, 70:30, 65:35 ... 15:85, 5:95, 0:100 v/v). Likewise, a fixed volume of pure petroleum products was mixed with varying quantity of solid particulates (0, 2, 4, 6, 8, 10 g). The specific Gravity (SG) and Interfacial Tension (IFT) of the pure samples, binary mixtures were determined according to ASTM D1298 and D971 standards, respectively. These physiochemical properties (SG and IFT) of pure and contaminated fuel samples were used to develop a mathematical model. The model was then simulated into a microcontroller-based detector. A microcontroller of PIC16f876 microchip with multiple input/output pins and a load cell sensor with real-time response was used. The microcontroller takes the reading of the weight of liquid from the sensor to get the SG and IFT of the liquid in real-time. Values of SG and IFT of pure and contaminated samples of petroleum products were obtained using the developed adulteration detector and compared with laboratory measurements and those obtained using Kay's mixing rule. Data were analysed using ANOVA at α 0.05.

The SG and IFT (dynes/cm) of the pure samples were (PMS) 0.833, 47.0; (AGO) 0.812, 28.0; (DPK) 0.803, 25.0, for liquid contaminants ranged from (PMS) 0.853-0.890, 44.6-25.0; (AGO) 0.807-0.804, 46.2-29.5; (DPK) 0.811-0.947, 46.4-38.0 and for solid contaminants ranged from (PMS) 0.887-0.910, 47.8-27.2; (AGO) 0.884-0.887, 29.2-30.0; (DPK) 0.817-0.857, 25.8-32.8, respectively. The SG and IFT from Kay's mixing rule ranged from (PMS) 0.851-0.900, 48.4-25.6; (AGO) 0.850-0.871, 40.1-35.4; (DPK) 0.864-0.881, 42.4-36.4, respectively. Adulteration of products was detected at 20.0-30.0% by volume and 10.0-20.0% by mass of contamination, respectively. The designed adulteration detector responded to the sample in real-time of 3-5s, displayed GREEN and RED for pure and adulterated samples, respectively, with their numerical SG values within $\pm 0.01\%$ of actual measurements. There was no significant difference between the actual and detected SG and IFT of the adulterated samples.

A device that detects petroleum products adulteration in real-time and ambient temperature was developed. The method can be adapted to real-time evaluation of similar binary mixtures.

Keywords: Fuel adulteration, Microcontroller, Fuel specific gravity, Interfacial tension

Word Count: 488

TABLE OF CONTENTS

Content	Pages
TITLE PAGE	i
CERTIFICATION	ii
DEDICATION	iii
ACKNOWLEDGEMENTS	iv
ABSTRACT	v
TABLE OF CONTENTS	vi
LIST OF TABLES	ix
LIST OF FIGURES	xiii
LIST OF ABBREVIATIONS	xvii
CHAPTER ONE: INTRODUCTION	
1.1 Background of the Study.	1
1.2 Factors Promoting Fuel Adulteration	3
1.3 Operational Adulteration	3
1.4 Specific objective of the study	4
1.5 Significance of Study	4
1.6 Scope and Limitations of the Study	4
CHAPTER TWO: LITERATURE REVIEW	
2.1 Chapter Overview	5
2.2 Existing Fuel Adulteration Detection Devices	8
2.3 Solid Particulate in Petroleum Products	10
2.4 Sources of Particulate matter	16
2.5 Characteristics of Solid Particulate	17
2.6 Effects of Solid Particulates Includes	18
2.7 Dust and Ash as Petroleum Products Particulate	18
2.8 Instrumentation and Control	18
2.9 Application of Instrumentation and Control	18

2.10	Engineering Structure and Materials	18
2.11	The latest in sensors usage and application.	19
2.11.1	Liquid and Gas Sensors	20
2.11.2	Special Sensors	21
CHAPTER THREE: MATERIALS AND METHODS		
3.1	Model Development	29
3.2	Kay Mixing Rule equation for Specific Gravity.	29
3.3	Kay Mixing Rule equation for Interfacial Tension.	29
3.4	Laboratory Analysis.	30
3.5	Contamination with Hard Particulate (Sand and Sawdust)	37
3.5.1	Materials and Method	37
3.6	Contamination with Hard Particulate (Ashes)	38
3.6.1	Materials and Method	38
3.7	Design Modelling of Adulterate Meter as a Device	42
3.7.1	Design Block Diagram of Adulterate-meter	43
3.7.2	Casing	46
3.7.3	Use of Sensor	47
3.7.4	The microcontroller	47
3.7.5	The LCD	50
3.7.6	The LED	52
3.8	Ergonomics of the Design	54
3.9	Design Simulation using Assemblage Language	55
3.10	Design in 2 and 3 Dimensional AutoCAD Drawing of Developed Adulterate-Meter	56
3.10.1	Brief Description of the Drawing	57
3.10.2	Developed Adulterate meter Performance Evaluation	59
3.10.2	Precautions	60
CHAPTER FOUR: RESULTS AND DISCUSSION		
4.1	Specific Gravity Result Obtained Using Kay-Mixing Rule	66
4.2	Interfacial Tension Result Obtained from Mixing Rule	75
4.3	Adulterate Meter Evaluation Results	83

4.4	Fuel Contaminated with Naptha	91
4.5	Fuel Contaminated with Lubricating Oil	93
4.6	Fuel Contaminated with Industrial Solvent (Alcohol)	99
4.7	Fuel Contaminated with Heavy Oil (Used Lubricant)	102
4.8	Adulterate meter Testing Result with Fuel Contaminated with Sand dust Particulate	104
4.9	Adulterate meter Testing Result with Fuel Contaminated with Sawdust Particulate	110
4.10	Adulterate meter Testing Result with Fuel Contaminated with Ashes Particulate	113
4.11	Adulterate meter Testing Result with Pump Station Fuel	118
4.12	Comparative Plots of the Experimental Result and Adulterate Meter Readings	119
4.13	Comparative Plots for the Adulterate Meter and Mathematical Correlation with Solid Particulate Adulterant	140
4.14	Result of Laboratory Biodegradability Test	149
4.15	Statistical Analysis	151
4.16	Frequency for the Adulterate Meter using Simulation window With Proteus	153

CHAPTER FIVE: SUMMARY, CONCLUSION AND RECOMMENDATIONS

5.1	Summary	154
5.2	Conclusion	155
5.3	Recommendations	155
5.4	Contributions to Knowledge	155
5.5	Suggestions for Further studies	156
	REFERENCES	157
	APPENDIX A	162

LIST OF TABLES

Table 4.1:	Specific gravity using Kay mixing rule for Petrol: kerosene system at 26 ⁰ C	68
Table 4.2:	Specific gravity using Kay mixing rule for Petrol: Diesel system at 26 ⁰ C.	69
Table 4.3:	Specific gravity using Kay mixing rule of Petrol: Water system at 26 ⁰ C.	70
Table 4.4:	Specific gravity result using Kay mixing rule of Petrol: Lubricating oil at 26 ⁰ C	71
Table 4.5:	Specific gravity result using Kay mixing rule of Petrol: Naphtha system at 26 ⁰ C.	72
Table 4.6:	Specific gravity using Kay mixing rule of Petrol: Commercial ethanol system at 26 ⁰ C.	73
Table 4.7:	Specific gravity result using Kay mixing rule of Petrol: Fuel oil system at 26 ⁰ C.	74
Table 4.8:	Interfacial tension using Kay mixing rule of Petrol: kerosene system at 26 ⁰ C.	76
Table 4.9:	Interfacial tension result using Kay mixing rule of Petrol: Diesel system at 26 ⁰ C.	77
Table 4.10:	Interfacial tension result using Kay mixing rule of Petrol: Water system at 26 ⁰ C.	79
Table 4.11:	Interfacial tension result using Kay mixing rule of Petrol: Lubricating oil system at 26 ⁰ C.	79
Table 4.12:	Interfacial tension result using Kay mixing rule of Petrol: Naphtha system at 26 ⁰ C.	80
Table 4.13:	Interfacial tension result using Kay mixing rule of Petrol: Alcohol system at 26 ⁰ C.	81
Table 4.14:	Interfacial tension result using Kay mixing rule of Petrol: Fuel oil system at 26 ⁰ C.	82

Table 4.14:	Adulterate meter evaluation result for binary mixture of Petrol: Water system.	84
Table 4.15:	Adulterate meter evaluation result for binary mixture of Kerosene: Water system.	85
Table 4.16:	Adulterate meter evaluation result for Binary mixture of Diesel: Water system	86
Table 4.17:	Adulterate meter evaluation result for binary mixture of Petrol: Diesel system	89
Table 4.18:	Adulterate meter evaluation result for binary mixture of Petrol: kerosene system.	90
Table 4.19:	Adulterate meter evaluation result for binary mixture of Diesel: Kerosene system.	91
Table 4.20:	Adulterate meter evaluation result for binary mixture of Petrol: Naphtha system.	92
Table 4.21:	Adulterate meter evaluation result for binary mixture of Diesel: Naphtha system	93
Table 4.22:	Adulterate meter evaluation result for binary mixture of Kerosene: Naphtha system	94
Table 4.23:	Adulterate meter evaluation result for binary mixture of Petrol: Lubricating oil system.	95
Table 4.24:	Adulterate meter evaluation result binary mixture of Diesel: Lubricating oil system.	96
Table 4.25:	Adulterate meter evaluation result for Kerosene: Lubricating oil system.	95
Table 4.26:	Adulterate meter evaluation result for Petrol: Fuel Oil system.	96
Table 4.27:	Adulterate meter evaluation result for Diesel: Fuel oil system.	97
Table 4.28:	Adulterate meter evaluation result for Kerosene: Fuel oil system.	98
Table 4.29:	Adulterate meter evaluation result for Petrol: Alcohol system.	99
Table 4.30:	Adulterate meter evaluation result using for Diesel: Alcohol system.	100

Table 4.31:	Adulterate meter evaluation result using for Kerosene: Alcohol system	101
Table 4.32:	Adulterate meter evaluation result using for Petrol: Heavy oil system	102
Table 4.33:	Adulterate meter evaluation result using for Diesel: Heavy oil system.	103
Table 4.34:	Adulterate meter evaluation result for Kerosene: Heavy oil system.	104
Table 4.35:	Adulterate meter evaluation result with Petrol Contaminated with Sand dust.	107
Table 4.36:	Adulterate meter evaluation result for Diesel Contaminated with Sand dust.	108
Table 4.37:	Adulterate meter evaluation result for kerosene Contaminated with Sand dust.	109
Table 4.38:	Adulterate meter evaluation result for Petrol Contaminated with saw dust.	110
Table 4.39:	Adulterate meter evaluation result for Diesel Contaminated with saw dust.	111
Table 4.40:	Adulterate meter evaluation result for kerosene Contaminated with saw dust.	112
Table 4.41:	Adulterate meter evaluation result for Petrol Contaminated with ash.	113
Table 4.42:	Adulterate meter evaluation result for Diesel Contaminated with Ash.	114
Table 4.43:	Adulterate meter evaluation result for kerosene Contaminated with Ash.	116
Table 4.44:	Adulterate meter evaluation result for Petrol, Kerosene and Diesel System.	118
Table 4.45:	Statistical Studies of Experimental Result and Models obtained.	152

LIST OF FIGURES

Figure 2.1:	IR sensors for the detection of adulteration.	7
Figure 2.2:	Experimental Set up for the actual implementation of fuel Adulteration detection	9
Figure 2.3:	Experimental set up using Image processing method	11
Figure 2.4:	Fuel Adulteration detection using litmus Paper	13
Figure 2.5:	Petroleum Volume Estimator and Tracker	15
Figure 2.6:	A Simple sensor	24
Figure 2.7:	Grain-size RFID chips	26
Figure 3.1:	Measuring the temperature/IFT of the Diesel sample	32
Figure 3.2:	Petroleum products adulterated with Naphtha and Alcohol	35
Figure 3.3:	Pure petroleum products samples	36
Figure 3.4:	Scale Measuring Ashes in a Petri dish	39
Figure 3.5:	Scale Measuring Sand Dust in a Petri dish	40
Figure 3.6:	Scale Measuring Saw Dust in a Petri dish	41
Figure 3.7:	Design Block Diagram of adulterate meter	43
Figure 3.8:	Picture of Sensor	45
Figure 3.9:	Circuit diagram of the sensor using a load cell	49
Figure 3.10:	The picture of Microcontroller	39
Figure 3.11:	The circuit diagram of microcontroller section	49
Figure 3.12:	The picture of LCD Screen	51
Figure 3.13:	The circuit diagram of LCD screen	52
Figure 3.14:	Circuit diagram of specific gravity meter with power supply.	53
Figure 3.15:	Circuit diagram of specific gravity meter with Power supply and Load Cell	54
Figure 3.16:	2 and 3 Dimensional AUTOCAD Drawings	58
Figure 3.17:	Samples of Adulterant (A-Alcohol, B-Used Lubricating Grease, C- Fuel Oil)	60

Figure 3.18:	Samples of Adulterant (D- Naphtha, E-Lubricating grease, F-Water)	61
Figure 3.19:	Samples of Adulterant (G-Petrol, H-Kerosene, I-Diesel)	62
Figure 3.20:	Adulterate meter detecting Impurity in Diesel	63
Figure 3.21:	Adulterate meter detecting Impurity in Kerosene	64
Figure 3.22:	Adulterate meter with no sample	65
Figure 4.1:	The designed Adulterate meter	113
Figure 4.2:	Specific Gravity versus Temperature of Petrol/ Water mixture	121
Figure 4.3:	Specific Gravity versus Temperature of kerosene/ Water Mixture.	122
Figure 4.4:	Specific Gravity versus Temperature of Diesel/ Water mixture.	123
Figure 4.5:	Specific Gravity versus Temperature of Diesel/ Petrol	124
Figure 4.6:	Specific Gravity versus Temperature of kerosene/Petrol.	125
Figure 4.7:	Specific Gravity versus Temperature of kerosene/Diesel mixture.	126
Figure 4.8:	Specific Gravity versus Temperature of Petrol /Naphtha mixture	127
Figure 4.9:	Specific Gravity versus Temperature of Diesel/Naphtha mixture.	128
Figure 4.10:	Specific Gravity versus Temperature of Petrol/Lubricating oil mixture	129
Figure 4.11:	Specific Gravity versus Temperature of Diesel / Lubricating oil mixture	130
Figure 4.12:	Specific Gravity versus Temperature of kerosene/ Lubricating oil mixture	131
Figure 4.13:	Specific Gravity versus Temperature of Petrol/Fuel oil mixture.	132
Figure 4.14:	Specific Gravity versus Temperature of Diesel/Fuel oil mixture	133
Figure 4.15:	Specific Gravity versus Temperature of Kerosene/Fuel oil mixture	134
Figure 4.16:	Specific Gravity versus Temperature of Petrol/Alcohol mixture	135
Figure 4.17:	Specific Gravity versus Temperature of Diesel / Alcohol mixture	136
Figure 4.18:	Specific Gravity versus Temperature of Kerosene/Alcohol mixture	137
Figure 4.19:	Specific Gravity versus Temperature of Petrol/Heavy Oil mixture	138
Figure 4.20:	Specific Gravity versus Temperature of Diesel / Heavy oil mixture	139

Figure 4.21:	Specific Gravity versus Temperature of Kerosene/Heavy oil mixture	140
Figure 4.22:	Specific Gravity versus Temperature of Petrol /Sand dust mixture	141
Figure 4.23:	Specific Gravity versus Temperature of Diesel /Sand dust mixture	142
Figure 4.24:	Specific Gravity versus Temperature of Kerosene /Sand dust mixture	143
Figure 4.25:	Specific Gravity versus Temperature of Petrol /Saw dust mixture	144
Figure 4.26:	Specific Gravity versus Temperature of Diesel /Saw dust mixture	145
Figure 4.27:	Specific Gravity versus Temperature of kerosene/Saw dust mixture	146
Figure 4.28:	Specific Gravity versus Temperature of Petrol/ Ash Oil mixture	147
Figure 4.29:	Specific Gravity versus Temperature of Diesel /Ash mixture	148
Figure 4.30:	Specific Gravity versus Temperature of Kerosene/Ash mixture.	149
Figure 4.31:	Biodegradation curve of the casing (Polyvinl sample).	151
Figure 4.32:	Microcontroller C Codes	154

CHAPTER ONE

INTRODUCTION

1.1 Background of the study

Adulteration is the introduction of a new or foreign substance into a product illegally for monetary gains. The result is such that the product does not conform to the requirements and specifications of regulatory bodies. Adulteration often distorts the properties of products and hence their performance. With enormous quantity of adulterants available in the market, and at relatively cheaper prices, fuel adulteration has developed into alarming proportions in several developing countries in the past few years. (Sengupta *et al.*, 2010). Adulteration of fuel can occur during refining, transportation and at point of sale of petroleum products. During crude oil production, reservoir fluids can be contaminated with mud filtrates, water and salts, which affect the properties and behaviour of the fluids (Kashefi *et al.*, 2012). Adulterated crude oil can affect pipeline systems and increase the cost of refining.

Transport fuels are subjected to more adulteration than crude oil. Premium motor spirit (Petrol) is popularly adulterated with naphtha, liquid natural gas, kerosene, industrial waste solvents, etc. This adulteration of fuel causes pollution, engine troubles and proves to be a costly affair for consumers. Diesel is also often adulterated with kerosene. Due to adulteration, many changes occur to the properties and original characteristics of the fuels and distort the internal combustion of fuels resulting in the release of harmful pollutants to the atmosphere. Some of the harmful gas emissions can cause respiratory disorders. Adulterants damage automobile engines and generators and lead to frequent engine failures and increased maintenance costs.

Causes of fuel adulteration include the following:

1. Scarcity of petroleum products.
2. Differential fuel tax systems and subsequent high price differentials in some countries, such that petrol and diesel are heavily taxed or unsubsidized while kerosene is kept at low prices
3. Availability and cheapness of adulterants.
4. Lack of effective monitoring system and low consumer awareness.
5. Non-availability of cheap, easy-to-use equipment for on the spot-checks of quality.

Some laboratory estimation of fuel adulteration is as follows:

1. Density Test: To measure the density of liquid samples, the use of hydrometer and sometimes densitometers can be done. This density method has the advantage of accuracy but suffers a few disadvantages. Densitometers are costly and need a controlled environment, which is often unavailable. The change in density is usually minimal to be easily detected
2. Evaporation Test: Evaporation techniques can detect very low concentrations (1 - 2%) of diesel in gasoline and fairly low concentrations (5%) of kerosene in gasoline. However, this is a laboratory technique and is not suitable for field use. (Takemi,2016)
3. Distillation Test: This procedure exploits the difference in the boiling points of different liquids comprising the fuel sample. Accurate distillation data for uncontaminated fuel is essential for comparison and precise results. However, the technique is not often suitable as the measurement setup is generally bulky, and the process is time-consuming.
4. Gas Chromatography: This is a prevailing method for the detection of high level of impurities rich in hydrocarbon. So the need of a skilled operator is required to work on the equipment and understand the results.

1.2 Factors Promoting Fuel Adulteration

Adulteration of gasoline is widespread in India, Asia, and several developing countries. According to Sengupta *et al.*, 2010), the factors which usually stimulate the practice of adulteration are:

- i. Dissimilarity in prevailing cost of prevailing automobile fuels which may be due to difference in the basic price and/or taxes and subsidies.
- ii. Unexpected fuel products scarcity during some periods and seasons.
- iii. Adulterants are readily available in the marketplace.
- iv. Low consciousness of adulteration prevalence amongst end users.
- v. Unrestrained guidelines in the production, supply and advertising chain for intermediates.
- vi. Lack of effective sanctions to deter recurrence.
- vii. Non-availability of easy and dependable instruments for on-the-spot checking of quality of the conventional automobile fuels.

1.3 Operational Adulteration

There are times when adulteration is inevitable or even desirable. These includes:

- a) Mixing Small amounts of distillate fuels like diesel or kerosene into automotive gasoline.
- b) Mixing gasoline in diesel with small volumes of disburshed waste of waste industrial solvents such as used lubricants which are costly to dispose in an environmentally approved manner.
- c) A blend of kerosene into diesel, often as much as 5-10% during fuel transportation via pipeline.
- d) Adding small quantity of heavier fuel oils into diesel.

1.4 Aim and Objectives

The aim of this study was to design and develop a scientific tool to detect the Adulteration of fuel samples in real-time using readily available liquid and particulate contaminants. The study involved the use of biodegradable raw materials that are small in size, light in weight, with a very low power consumption, and ease of operation. The specific objectives of this study were:

1. To generate reliable experimental data on the Specific Gravity of conventional fuel as it's varies with temperature, at varying quantity of Adulterants for liquid and solid contaminants.
2. To generate reliable experimental data on the Interfacial Tension of conventional fuel at room Temperature, with varying quantity of Adulterants for liquid and solid contaminants.
3. To use the data obtained, alongside with the physiochemical properties of Fuel sample to develop some mathematical models.
4. To optimize the Mathematical models, and then simulate the optimized model into an adulterated fuel detector.
5. To evaluate and validate the developed fuel detector using solid and liquid contaminants.

1.5 Significance of the study.

1. Fuel demand and usage has greatly increased. A direct result of this is an increase in the level of fuel adulteration. Significant number of lives has been recorded lost in the past years as result of adulteration in fuel. This proposed study was meant to minimize problems caused by fuel adulteration, which includes: Health-related problems, Engine Failure and knocking e.t.c
2. This study enhances and promotes high quality production and distribution of fuel. This will be achieved without increasing production and transportation costs, and minimizes fuel adulteration and subsequent associated problems.
3. This research work also enables real-time detection of fuel adulteration.

1.6 Scope and Limitations of the Study.

- This study is limited to detection of adulteration of fuel at tropical temperatures, only the commonly used contaminants in Nigeria were considered. However, the results from this work were also applicable to real-time evaluation of similar binary mixtures.

CHAPTER TWO

LITERATURE REVIEW

2.1 Chapter Overview

Adulteration of petroleum products exists in various forms, with the type and quantity varying from place to place, from the point of production in the reservoir to the point of distribution and point of sales. Profitability, availability and the ability to blend are prominent factors governing the choice of adulterants (Dutta, *et al* 2003). Adulteration varies from the use of small amounts (less than 30%) of distillate fuels like diesel or kerosene into automotive gasoline; use of small amounts of used industrial solvents such as used lubricants into gasoline and diesel. Some of the reasons for adulteration are increasing in fuel price and availability of adulterants which are easy to mix and have similar chemical characteristics of the fuels. There are several petroleum products which are close substitutes of petrol and diesel and are available at considerably lower prices. The consequence is that these products are widely used as adulterants (Dauda ,2012). More so, it is widely believed that the easiest way of reducing the cost of fuel is to add adulterants. Unfortunately, the ripple effect is the lowering of the quality of the automobile fuels and contribution to environmental and health hazard.

2.2 Existing Fuel Adulteration Detection Devices

Isehunwa and Falade (1993), reported modified Kay's mixing rule that exists if we treat an adulterated petroleum product as a fluid mixture, they stated that Kay's mixing rule may be applied at any fixed temperature: Therefore, in an adulterated fluid system, the degree of adulteration in a mixture can be connected to the properties of the uncontaminated fluid and the mixture.

Roy,(1999) detected Adulteration using Optical Fibre Sensor: The techniques relates variations in physical properties to the concentration of monochromatic light. Optical fibre acts as a wave guide for light if the covering has a lower refractive index than that of fibre material. When the light is reflected from the interface of the fibre, the field associated with the light wave extends beyond the interface into the surrounding medium. The amplitude of this field decreases exponentially with distance from the interface. If the surrounding material absorbs some part of the light propagating through the fibre, the power received at the other end of the fibre will be less by the amount absorbed by the surrounding medium.

Thomas et.al. 2004 reported that adulteration detection can be achieved using Sound/Ultrasound. Adulteration results into an alteration in density and the fuel's viscosity. Since these factors influence the speed of sound in a fluid, it is predictable that the speed of sound in adulterated fuel would be different from that in unadulterated fuel. We have two basic approaches for determination: the Pulse-Echo (PE) and Continuous Wave (CW) method.

Yadav et al., 2005 reported the use of level detection using IR Sensor. Figure 2.4 presents a setup of detecting fuel adulteration using IR sensors experimentally. Fuel tank lid is opened and then the fuel filling into the tank starts, a small quantity of it goes to a small chamber of capacity 50ml where the adulteration of fuel is being measured.

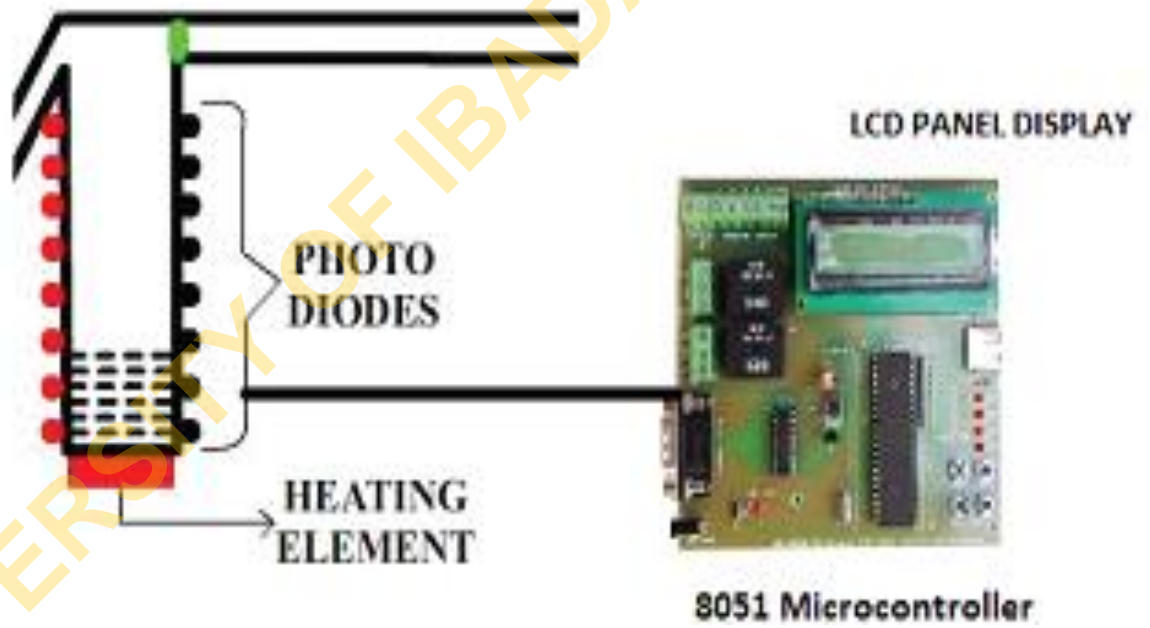

Figure 2.1: IR sensors for the detection of fuel adulteration (www.digikey.com.)

Isehunwa, et al. 2012, reported that salinity affects the reservoir fluids. The light crude was shown to demonstrate increasing interfacial tension with temperature while the heavy crude showed a decrease in interfacial tension with increase in brine salinity, Hence the effect of salinity plays a vital role in detecting adulteration.

Olanisebe, et al. 2013, reported the use of water – cut meter especially when fuel is adulterated with water, wide range of methods has been used to measure the BSW of crude oil during production. (EESFLOW, 2007). A technique of measuring BSW using dielectric-constant was developed in 1962 by Warren .

Dey and Dwivedi (2014) reported a method of detecting fuel adulteration in automobiles by the use of a camera, placed at a fixed position at a distance of approximately 20 centimetres. A Raspberry-pi automatically heat a fixed chamber and signals are transmitted.

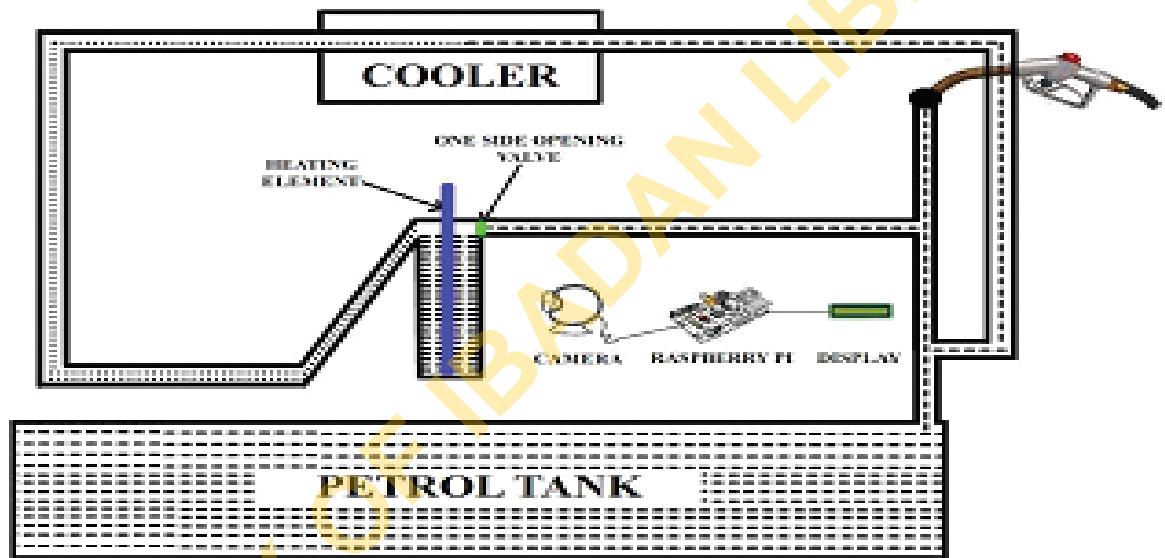

Figure2.2: Experimental setup for the actual implementation of fuel Adulteration.

Ranjan, et al. (2014) developed a compact fuel adulteration detection kit, which can monitor fuel quality at the distribution point. The device is designed using TSM BAW micro acoustic sensor with dual density-viscosity sensing and integrated temperature sensor.

Felix et al. (2015) further explained the usage of Raspberry-pi: A picture taken by the camera is fed into a microcontroller that is programmed in such a way that it calculates the percentage of adulteration by comparing the level of fuel left out in a glass tube by using image processing technique. The microcontroller is interfaced to an LCD that displays the percentage of impurity in the fuel. It fuel gets evaporated, and only the adulterant remains in the glass tube. Then this adulterant is transferred to a glass tube of 50ml volume. The camera takes a picture of the glass tube at a resolution of 320*240 pixels. It sends it to the Raspberry-pi for processing. Raspberry pi processes the image to find the level of the liquid.

Felix et al. (2015) used an experimental form of image processing method, the adulterated fuel is heated for the same amount of time—likewise the entire petrol in the adulterated mixture. The picture taken by the camera is fed to a microcontroller and programmed to calculate the percentage of adulteration.

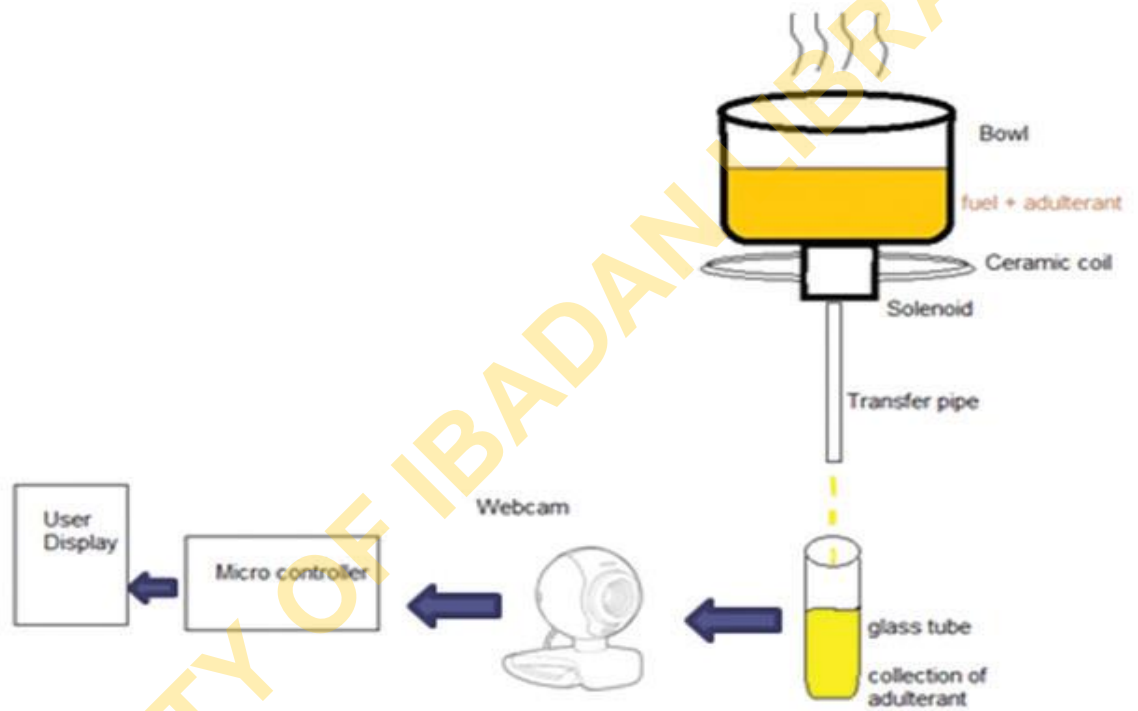

Figure 2.3: Experimental Setup using Image processing method.

Mishra et al., (2015) reported the use of boiling point in detecting adulteration. In this method, a sample of the fuel being filled is heated to a temperature equal to petrol or kerosene's boiling point. Such that the amount of impurity in the fuel can be detected.

Dharurkar and Wadhekar (2016), Noted that, Sensors which are reusable, can play a critical role in finding out the percentage of fuel adulteration. (Wiley, 2013) Fibre Optic Sensors were used for determining adulterated concentrations of Petrol, Diesel and Kerosene.

Babu et al. (2017) used a simulation-based fuel adulteration detection approach where Computer-aided design is used to simulate data samples. Digital Data Decisions were given in which the signal conditioning concept was used.

Kude and Patil (2017) reported adulteration detection using an arm controller where a small detection device is used for density measurement. Adulteration detection is done by determining comparing test results with a standard reference sensors which provided inputs to the system controller through signal conditioning. The output is displayed on LCD.

Olotu et al. (2018) conducted a survey to ascertain the prevalence of petroleum products adulteration in the six geopolitical zones of Nigeria and developed a mathematical model which detected adulteration between 20 - 40% concentration by volume of contamination.

Fadairo et al, (2020) reported the use of filter paper to detect adulteration of fuels. They acknowledged the use of litmus paper as the most efficient method to detect the rate of fuel adulteration. However one of its major limitations is that it is not operated in real time as it takes about an hour to make deductions .

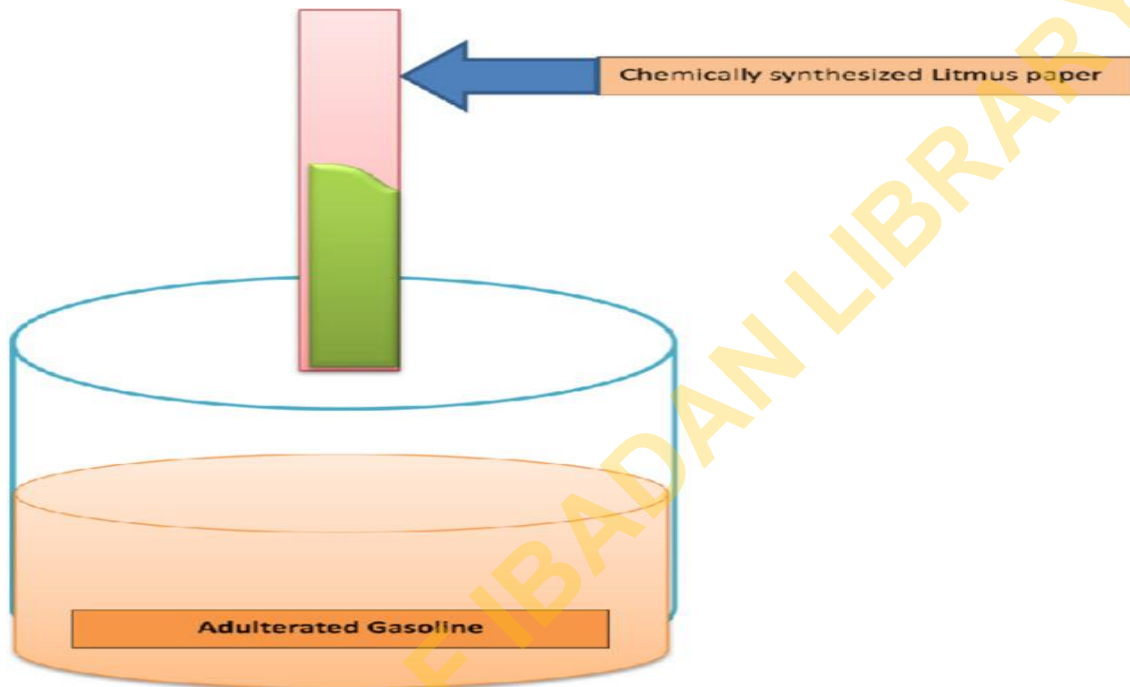

Figure 2.4: Fuel Adulteration detector using litmus Paper.

Otega *et al*, (2020) presented the design and fabrication, and use of a portable electronic device for petroleum volume estimation, adulteration sensing, and product tracking during transportation. The device known as the Petroleum Product Volume Estimator and Tracker (PPVET), can be used to measure the volume of a petroleum product in calibrated or uncalibrated tanks, and may prove to be valuable substitute for manual tank gauging commonly used in the Energy Sector (Oil and Gas). With its ability to characterize the chemical signature of pure petroleum products using electronic vapour emission analysis, PPVET can be used to test for the presence of adulterants in petroleum products.



(a)

(b)

(c)

Figure 2.5: Petroleum Volume Estimator and Tracker.

From the review of literature, the design and development of a device to detect adulteration of fuel based on its specific gravity and interfacial tension (IFT) in real-time have not been reported. This brought the conception of this research work. This work adopted the principle of hydrometer to design and develop a new device for real-time adulteration detection. An extension to solid particulates has been done since it has been observed that petroleum products can be contaminated with liquid adulterants and some common solid particulate such as sands, dust, ashes etc.

2.3 Solid Particulate as Petroleum Products Contaminants.

There are lots of suspended solid and liquid particles in air, they are called particulate matter and could be very hazardous, if not properly and adequately controlled. They include both organic and inorganic particles, dirt, pollen, soot, smoke, and liquid droplets. These particles vary greatly in size, composition, and origin. (Pettit, *et al.*, 2019). It is mostly categorised into two main groups based on their size:

- **Inhalable coarse particles:** These particles range from 2.5 micrometres to 10 micrometres in diameter (PM₁₀ – PM_{2.5}) depending on its constituents.
- **Fine particles:** These particles are found in smoke and haze with a size up to 2.5 µm (PM_{2.5}).

While Inhalable coarse particle is found near roadways and dusty industries, fine particles can be directly emitted from sources such as forest fires, or they can form when gases emitted from power plants, industries and automobiles react in the air.

2.4 Sources of Particulate Matter

Particles originate from a variety of stationary and mobile sources and may be directly emitted (primary emissions) or formed in the atmosphere (secondary emissions) by transformation of gaseous emissions.

Primary emissions are derived from both human and natural activities. A significant portion is generated from a variety of human (anthropogenic) activities including agricultural operations, industrial processes, burning of wood and fossil fuels, construction

and demolition activities, and entrainment of road dust into the air. Natural (no anthropogenic or biogenic) including windblown dust and wildfires. (Lorenzo, *et al.*, 2010)

2.5 Characteristics of a Solid Particulate

The basic characteristics of solid particulate includes

- a) **Particle Size**
- b) **Surface Area**
- c) **Particle Shape/Angularity**
- d) **Hardness**
- e) **Density**
- f) **Composition**
- g) **Polarity**
- h) **Magnetic Susceptibility**
- i) **Conductivity**
- j) **Particle Count**
- k) **Surface Removal**

2.6 Effects of Solid Particulates includes:

1. Restriction of Oil Flow and Part Movement.
2. Increased Consumption of Lubricants and Filters.
3. Higher Energy Consumption and Environmental Impact.

2.7 Dust and Ash as Petroleum Product Particulate.

Dust comprises of fine solid matter. It's commonly made up of highest percentage of the solid matter in the atmosphere which comes from different source such as soil, dust which is lifted by wind, explosive igneous activities, air pollution (<https://en.wikipedia.org/2017>). Dust in residential environment, work place, and other human environments contains small amounts of plant pollen, human and animal hairs, textile fibres, paper fibres, minerals all from outdoor soil, and also those found in the local environment. Ashes are predominantly found in our environment from cigarette waste pan, corn seller, incinerators etc (Mahendra *et al.*1993).

2.8 Instrumentation and Control

Control Engineering is the way in which the system response of what was inputted into a definite system responded to its output. The evaluation of the system response by developing a mathematical model for the system is also termed control design engineering (Roland,2001). The important principle of any control system is the ability to quantify the output of the system because such system is aimed at giving a specific or desired result for instance in the design of equipment and device with specified behaviour in a given environment. This system must also be able to take corrective measures if the yielded values is different from some desired value.

2.9 Application of Instrumentation and Control

- i. Household Instrumentation System
- ii. Automotive
- iii. Aircraft
- iv. Laboratory instrumentation

2.10 Engineering Structures and Materials.

The study of engineering structures and materials with respect to sensor science and engineering has proven to be relevant over the years to virtually all aspects of life, including security, observation, and general awareness. Sensors are crucial to industrial claims being used for process control, monitoring, and safety. There are many significant

inventions, and discoveries begin made daily. Micro- and nanotechnology, novel materials, and smaller, smarter, and more operative electronic systems will play an significant role in sensors' future. For example, new nanowire-based materials with unique sensing properties can provide higher sensitivity, greater selectivity, and possibly improved stability at a lower cost.

2.11 The latest in Sensors Usage and Applications.

- i. A geophone is a device analogue or digital, that converts movement of ground velocity into voltage, which may be recorded at a place called recording station. The deviation of this measured voltage from the baseline is called the seismic response. Geophones have over the years been passive analogue devices and typically comprise a spring-mounted magnetic mass moving within a wire coil to generate an electrical signal. Recent designs have been based on micro electromechanical systems technology, which produces an electrical response to ground motion through an active feedback circuit to maintain the position of a small piece of silicon.
- ii. A hydrophone is a form of microphone designed to be used underwater for recording or listening to underwater sounds. Most hydrophones are based on a piezoelectric transducer that generates electricity when subjected to a pressure change. Such piezoelectric materials, or transducers, can convert a sound signal into an electrical signal since sound is a pressure wave. Some transducers can also serve as a projector. Still, not all have this capability, and some may be destroyed if used in such a manner. It can "listen" to sound in the air but will be less sensitive due to its design as having a good acoustic impedance match to water, which is a denser fluid than air. Likewise, a microphone can be buried in the ground or immersed in water if put in a waterproof container.
- iii. The use of microphones can be used in many applications such as telephones, open address systems for concert halls and public events, motion picture production, online and recorded audio engineering, two-way radios, and megaphones radio and television propagation. (Kude, 2017) Several microphone types are in use, employing different methods to convert the air pressure variations of a sound wave

to an electrical signal. A complete microphone also includes a container as such proposes a structure that can be realised using micro electromechanical systems technology (Ganji,2005). The signal from the element is brought to other equipment, and often an electronic circuit to adapt the capsule's output to the equipment being driven. A wireless microphone contains a radio transmitter.

- iv. A seismometer: This is an instrument used to detect the motion on land, caused by natural disaster such as tremor, a volcanic outburst, or the use of explosives. Records of seismic waves allow seismologists to map the Earth's internal and locate, measure the size of events like these. The qualified motion formed between the weightiness and the structure provides a upright ground motion dimension.

2.11.1 Liquid and Gas Sensors

- i. Carbon dioxide sensor: To effectively measure carbon dioxide in any given area, Carbon dioxide sensor or CO₂ sensor is the instrument most suitable. The principle of operation is with the use of infrared gas sensors, hybrid organic and inorganic nanomaterial and chemical gas sensors. Measuring carbon dioxide is important in monitoring well ventilated rate of indoor air quality, so as to avoid indoor air pollution. The lungs' function in a capno graph device, and many industrialized processes.
- ii. Carbon monoxide detector. The measurement or detection of carbon monoxide detector in an environment is very important for human and global health, so as to prevent carbon monoxide poisoning . Dale, 2009 reported a set up by constructing a homemade chamber from a readily available components in order to detect the gas. He made use of Electrical gadgets, sensor, probes e.t.c. In the setup, the presence of CO increases sensor conductivity depending on the gas concentration in air, its also requires a specific heat and measurement timing profile for proper operation. Carbon monoxide is a colourless,

tasteless, and odourless composite produced by unfinished burning of carbon-containing tools.

- iii. A Chemiresistors is a form of a gas sensor; it can be manufactured at a very low cost, yet with so many applications. It's a chemical sensor that relies majorly on the interaction between the chemical, the sensing materials and the analyte varies from a covalent bonding and electrovalent bonding interaction to form the identity or its molecular recognition. In other chemiresistors. This enhances the rate at which the amount of analyte present can be measured. The hydrocarbon components of any hydrocarbon-rich gas mixture occurs is called the hydrocarbon dew point, the temperature at which its condenses is called cricondentherm.
- iv. Hydrogen sensor: The presence of hydrogen gas in a given vicinity is detected by a hydrogen sensor. They contain micro-constructed point-contact hydrogen sensors and can also be used to trace hydrogen leakages. They are usually cheap, compact, resilient, and easy to keep compared to the common gas detecting instruments/device. In other to measure the level of hydrogen sulphide in a given space, an hydrogen sulphide sensor is used. This is prepared in the laboratory by the action of dilute sulphuric acid on iron sulphide. The use of concentrated sulphuric acid and nitric acid may not be applicable for this process as they oxidise hydrogen sulphide to sulphur.
- v. A nitrogen oxide sensor or NO_x sensor is used to detect nitrogen gas or oxides in the environments mostly from automobiles exhaust, its typically a high-temperature device built to be used with ease operation.
- vi. A gas detector is a device that detects gases in a given environment, often as part of a safety arrangement. This type of tools is used to detect a gas leak or other emissions. It can interface with a control system so a process can be automatically shut down. A gas detector

can sound an alarm to operators in the area where the leak is occurring, allowing them to leave. This type of device is necessary because many gases can be dangerous to organic life, such as humans or animals.(Edaphic Scientific Knowledge Base, 2021).

- vii. Gas leak detection can best be described as the process of recognising possibly dangerous gas escapes by devices that makes use of a suitable sensor. Lately, infrared imaging sensors is commonly used. Soil moisture sensors measures the volumetric water content in soil as its relates to matric potential. It can also use some other properties of the soil such as electrical resistance, dielectric constant, or interaction with neutrons, as a substitution for the moisture content. The moisture content in a giving soil sample varies depending on some important factors such as environmental factors(soil type, temperature, or electric conductivity). Furthermore, portable probe instruments can be used by farmers or gardeners. Soil moisture sensors typically refer to sensors that estimate volumetric water content. Another class of sensors measures another property of moisture in soils called water potential. These sensors are usually referred to as soil water potential sensors and include Tensiometer and gypsum blocks. (Edaphic Scientific Knowledge Base, 2021)
- viii. An airflow meter is a device that measures airflow, i.e. its states the rate at which air flows through a channel. However, It does not measure the volume of the air being conveyed through the tube. It determines the mass of air flowing through the device per unit time. Thus, air flow meters are basically an application of mass flow rate meters for an exceptional medium. Typically, mass air flow measurements are expressed in the units of kilograms per second (kg/s) (Edaphic Scientific Knowledge Base, 2021)
- ix. As reported by Noor in 2016, The flow sensor is the quantification of bulk fluid movement. Flow can be measured in a variety of ways. Positive-displacement flow meters accumulate a fixed volume of

fluid and then count the number of times the volume is filled to measure flow. Other flow measurement methods rely on the flowing stream's forces. It overcomes a known constriction to calculate flow. Flow may be measured by measuring the velocity of fluid over a known area. Tracer processes may reduce the flow rate from the change in concentration of a dye radioisotope for enormous flows.

- x. Water metering are used to measure the volume of water consumed in a giving environment be it habitable or non-habitable ,also in a commercial environment .The water is often supplied by a public water supply system. Some electronic meter registers can display rate-of-flow in addition to total usage. There are several types of water meters, they depend majorly on the flow measurement method and the type of end-user, the required flow rates, and accuracy.

2.12 Special Sensors

The latest sensors have more features, they are the twenty first century sensors, they are user-friendly, accessible, and flexible. So there is a standard shift in the sensor industry with the integration of new technologies to make sensors smoother and intellectual. Ordinary sensors are still used in many application, but innovation and advancement in microelectronics are taking sensor technology to an entirely new level. The functionality of ordinary sensors has expanded in many ways, and these now provide several additional properties. Latest Sensors are becoming more intelligent, providing higher accuracy, flexibility, and easy integration into distributed systems. Sensors are an input devices that accepts and returns an external signal. Some sensors come incorporated with many sensing necessities and read-out circuitry in a single silicon chip, providing high precision and several functions.(Sani *et al* ,2020).

Intelligent sensors use the standard wireless network interfaces to communicate with one another or with microcontrollers (MCUs). The network interface makes data transmission easier while also expanding the system. Manufacturers can diagnose sensor faults and

guide users to troubleshoot them remotely through the computer network (Eletimes, 2019).

a. Internet of Time (IOT) type of Sensors

For an effective monitoring and control purposes, latest sensors are attached to a computer network using the Internet. IOT systems have wide applications across industries with their unique elasticity in providing enhanced data assemblage, automation, and operation. Such application includes Temperature, proximity, pressure, RF sensors, pyro electric infrared (PIR) sensors, water-quality sensors, chemical sensors, smoke sensors, gas sensors, liquid-level sensors, automobile sensors, and medical sensors

b. Pollution Sensors

Most air pollution sensors focuses on about five requirements: particulate matter, ozone (O_3), carbon monoxide (CO_2), sulphur dioxide (SO_2), and nitrous oxide (NO_2).They are slightly expensive for general use such as indoor and outdoor environment

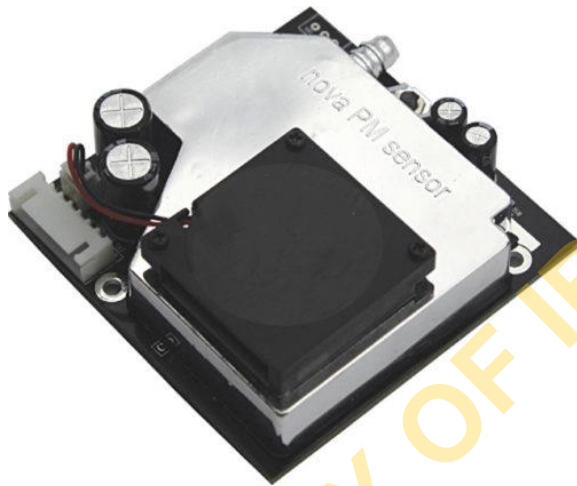

Figure 2.6: A simple sensor. (Sani,2020).

c. **Radio-Frequency Identification (RFID)**

They are chips sensors as small as a grain of rice; it can be inserted directly under the skin layer for ID cards. There is a trend to use RFID chips in many products, including contactless bank cards and Oyster cards. There are also cases where chips are implanted in pets and cattle for monitoring.

UNIVERSITY OF IBADAN LIBRARY



Figure 2.7: Grain-size RFID chips. (Sani,2020).

d. Wearable Sensors:

Wearable sensors are the type of sensors mostly used medically, GPS, for inertial measurement unit (IMU), and optical services. Sensors are also integrated into various equipment such as, eyeglasses, headphones, and smartphones. An IDTechEx report forecasts optical, IMU, and GPS sensors to dominate the sensors market in revenue by 2022.

e. Fuel Quality Sensor

Fuel Quality Sensors were launched in the twenty first century ,they constantly monitors the quality of diesel fuel used for trucks, construction machinery, generator, etc., and the presence and ratio of bio-diesel. The method of detection is via the use of heat and are not affected by the fuel oil, they have also been used in:

1. Detection of kerosene level in the diesel oil
2. Prevention of the use of poor quality oil and constant monitoring, whether diesel oil in a fuel tank has been adulterated.
3. The detection of biodiesel fuel oil (mixed rate), constant monitoring of presence or absence and the ratio of biodiesel has an adverse effect and shortens the life of the device if used at a high rate.
4. Water filling detection detects if a certain amount of water (e.g., rainwater) gets mixed in a fuel tank.

CHAPTER THREE

MATERIALS AND METHODS

3.1 Models

According to Isehunwa and Falade (1993), any volumetric or thermodynamic property of a fluid may be expressed as:

$$f = f(P, T, X) \text{-----}(3.1)$$

Where,

P= Pressure

T= Temperature

X=Composition

If we select some properties of the mixture (A_i) such as Specific gravity (SG) and/or Interfacial Tension (IFT), at any temperature, we have:’

$$X_i = f(\text{S.G, IFT})\text{-----}$$

(3.2)

The degree of adulteration in a mixture can be related to the properties of the pure fluid and the mixture.

b. Likewise Olotu (2018), applied this principle of hydrometer using specific gravity of the fuel both at the surface and at the interface

$$SG = \rho_l / \rho_w = \beta R a - \frac{\pi D \gamma l}{g} + \rho a \text{-----} (3.3)$$

Where,

D = diameter of the stem at scale reading = 25mm

$$\gamma(T) = \gamma_0 (1 - T/T_c)^u \text{-----} (3.4)$$

T is the temperature obtained from the experiment as the critical temperature, at which the interface becomes unstable, and u is a critical exponent it’s been calculated to be about

1.222 for organic liquids where γ^0 is the Experimental Interfacial Tension, $\gamma(T)$ is the computed interfacial tension at critical Temperature T_C . Therefore Equation (3.5) and (3.6) were merged together,

$$SG = \rho l / \rho w = \beta R - (\pi D \gamma T / g) + \rho a \text{ ----- (3.5)}$$

Where,

g = local acceleration of gravity = 10m/s

ρa = density of air = 1.225kg/m³

ρw = density of water = 1

$\gamma l = \gamma(T) = \text{IFT}$

β = Correlation Factor

Ra = calibration reading in air.

3.2 Kay Mixing Rule Equation for Specific Gravity .

Kay mixing rule was modified as ,

$$SG = X_1 Y_1 + X_2 Y_2 + \theta \text{ ----- (3.6)}$$

Where θ is the correlation Factor.

3.3 Kay Mixing Rule Equation for Interfacial Tension. .

Kay mixing rule for Interfacial Tension at ambient temperature was also modified as

$$IFT = Z_1 Y_1 + Z_2 Y_2 + \theta \text{ ----- (3.7)}$$

Where θ is the correlation Factor.

3.4 Laboratory Analysis

Materials and Method

- **Materials:** 250ml measuring cylinder, Beakers, adulterate- meter, Thermometer, Hydrometers, Tensiometer 250ml diesel, 250ml kerosene, 250ml petrol, 150ml water. 150ml naphtha, 150ml alcohol, 150ml lubricating oil, 150ml Healy oil, 100ml fuel oil.

Pure fuel sample served as control, it was obtained from a local pump station in Lagos.

- **Water:** Distilled Water was bought from the department of Petroleum Engineering, University of Ibadan.
- **Petrol:** Samples were bought from a local pump station in Lagos Nigeria. ,Eti –Osa Local Government, Lagos –State.
- **Kerosene:** Samples were bought from a local pump station in Lagos Nigeria. ,Eti –Osa Local Government, Lagos –State.
- **Diesel:** Samples were bought from a local pump station in Lagos Nigeria. ,Eti –Osa Local Government, Lagos –State.
- **Naphtha:** Naphtha is a flammable liquid hydrocarbon mixture, often times produced from natural gas condensates; sample was retrieved from Port –Harcourt refinery company limited, km2 Alesha Eleme, Port-Harcourt.
- **Lubricating oil:** Lubricating oil are called lubricant, it's a class of oil used to reduce the friction, heat and wear between mechanical components that are in contact with each other. Samples were retrieved from a Local filling station, ,Eti –Osa Local Government, Lagos –State.
- **Heavy oil (Used Lubricating oil):** Lubricating oil that has been reused severally were collected from a mechanic workshop,Eti –Osa Local Government, Lagos –State ,without any treatment , was subjected to these test.
- **High –Pour fuel oil (From Polyethylene):**The sample was a product of pyrolysis of waste polyethylene (Olotu 2015), the mixture is heated, under a high heating rate but a low controlled reaction temperature, there was a homogeneous mixing by rigorous shaking at a very high melting temperature. The filtrate, the liquid product which is the fuel oil is colourless with a characteristic odour of kerosene which increases in volume with cooling.
- **Industrial solvent (Alcohol):** Dry alcoholic beer was retrieved from a local market, at Eti – Osa local market.

Method: Hydrometers were carefully washed with soap, dipped in water followed by disinfected water, and were allowed to dry thoroughly.

Petroleum product samples were prepared at ambient temperature; adulterated fuel samples were prepared by varying the concentration of each sample with a known quantity

of an adulterant. Adulterant samples used were Water, Petrol, Kerosene, Diesel, Naphtha, lubricating oil, Heavy oil (Used Lubricating oil), Fuel oil (Polyethylene), Industrial solvent (Alcohol). Adulterant with nominal mole percentage of binary mixtures in 95 mole% for petrol and 5 mole% for each adulterant was prepared for 24 different samples as follows: Petrol -water; Kerosene - water;

Diesel - water; Petrol - diesel; petrol - kerosene; Kerosene – diesel, Petrol – Naphtha, Diesel - Naphtha; Kerosene - Naphtha; Petrol – Lubricating oil; Diesel – Lubricating oil; Kerosene - Lubricating oil, Petrol – Fuel oil(polyethylene); Diesel - Fuel oil(polyethylene); Kerosene - Fuel oil(polyethylene); Petrol – Industrial Solvent(Alcohol); Diesel - Industrial Solvent(Alcohol); Kerosene - Industrial Solvent(Alcohol); Petrol – Lubricating oil, Diesel – Lubricating oil, Kerosene – Lubricating oil, Petrol – Heavy oil(used Lubricating oil), Diesel - Heavy oil(used Lubricating oil); Kerosene - Heavy oil(used Lubricating oil).The percentage concentration by volume of each sample was varied up to 95% adulteration by volume ratio, hydrometers readings were properly recorded, likewise the interfacial tension of each sample using a Tensiometer.



Figure 3.1: Measuring the Temperature of the Diesel sample.



Figure 3.2: Measuring the Temperature of the Diesel sample.



Figure 3.2: Petroleum Products Adulterated with Naphtha and Alcohol.



Figure 3.3: Pure product samples

3.5 Contamination with hard Particulate (Sand and Sawdust).

Petroleum Products (Petrol, Diesel, and kerosene) fuel is fairly unpolluted when it leaves the refinery, but becomes contaminated each time it is transported or often put in storage with sand and sawdust. The fuel sample with constant volume were prepared with a known quantity of dust as an adulterant. Dust was retrieved from a vacuum cleaner dispenser at the Nicon Hilton Hotel, Lagos, Nigeria, and Sawdust were retrieved from a local Sawmill, Eti -Osa, Lagos –State.

3.5.1 Materials and Method

- **Materials:** 250ml measuring cylinder, weighing balance, petri-dish beakers, thermometer, specific gravity meter, 250ml diesel, 250ml kerosene, 250ml petrol, 20kg Sand dust, and Sawdust

Method:

Specific gravity meter containers were thoroughly washed with detergent, rinsed with water followed by distilled water, and were allowed to dry thoroughly. Petroleum product samples were prepared at ambient temperature, petrol, kerosene, and diesel (60ml) each, poured into the Adulterate - test meter for evaluation, till the sample touches the sensor (the tip) of the device and the specific gravity of each sample was recorded. The light-emitting diode indicator is also noted. Likewise, after sieving into the finest particle size, the mass of dust (sand and saw) was prepared in turn of 2 kg, 4 kg, 6 kg, 8 kg, and 10 kg. After this, contaminated sample was poured into the test meter for evaluation. The sample touches the sensor (the tip) of the device, and the specific gravity of each sample was recorded. The light-emitting diode indicator was also noted.

3.6 Contamination with Hard Particulate (ashes)

The quantity of inorganic non-combustible materials of a fuel is a measure of its ash content . It contains it ranges from 0.1%- 0.2%. They naturally occur in crude oil; others are present due to adulteration during storage or distribution. Petrol, Diesel, and kerosene fuel is fairly clean when it leaves the refinery, but becomes contaminated each time it is transferred or stored. For the device testing, the fuel sample with constant volume was prepared with a known quantity of ash as an adulterant/contaminant.

Materials and Method

- **Materials:** 250ml measuring cylinder, weighing balance, Petri dish, beakers, thermometer, specific gravity meter, 250ml diesel, 250ml kerosene, 250ml petrol, 20gs of ash.

Method:

Specific gravity meter containers were thoroughly washed with detergent, rinsed with water followed by distilled water, and were allowed to dry thoroughly. Petroleum product samples were prepared at ambient temperature, petrol, kerosene, and diesel (60ml) each, poured into the test meter for evaluation, till the sample torches the device's (the tip) of the device the specific gravity of each sample was recorded. The light-emitting diode indicator is also noted. Likewise, ash was obtained from a roasted corn seller at Eti-Osa local government area Ajah. After sieving into the finest particle size, the mass of ash was prepared in turn of 2 g, 4 g, 6 g, 8 g, and 10 g. After this, the contaminated sample was poured into the test meter for evaluation. The sample torches the sensor (the tip) of the device, and the specific gravity of each sample was recorded. The light-emitting diode indicator was also noted



Figure 3.5: Scale Measuring Ashes in a Petri dish



Figure 3.5: Scale Measuring Sand dust in a Petri dish

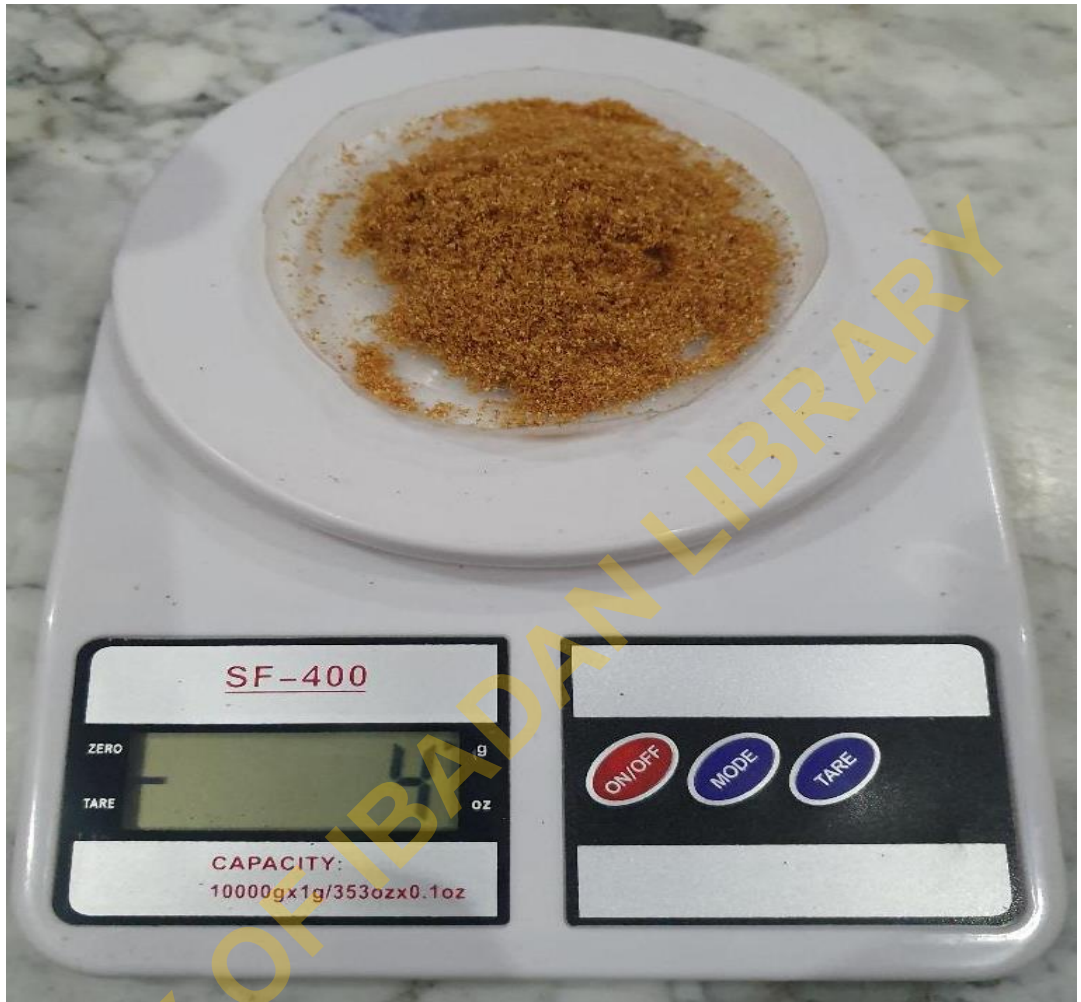

Figure 3.6: Scale Measuring Sawdust in a Petri dish

3.7 Design Modelling of Adulterate Meter as a Device

The project described in this report is a fuel adulteration detector using a chemical property of fuel which is impurity sensitive, its specific gravity, ITF/FT as they vary with temperature. A specific gravity meter for fuel is designed around a microcontroller device and a load cell sensor. The microcontroller controls the functionality using a program written in assembly language and installed on it, embedded in a casing, biodegradable polyethylene structure. The detector circuit's output signals were conditioned to create outputs that can be measured with a colour display and numerical values on the meter.

3.7.1 Design Block Diagram of Adulterate – meter

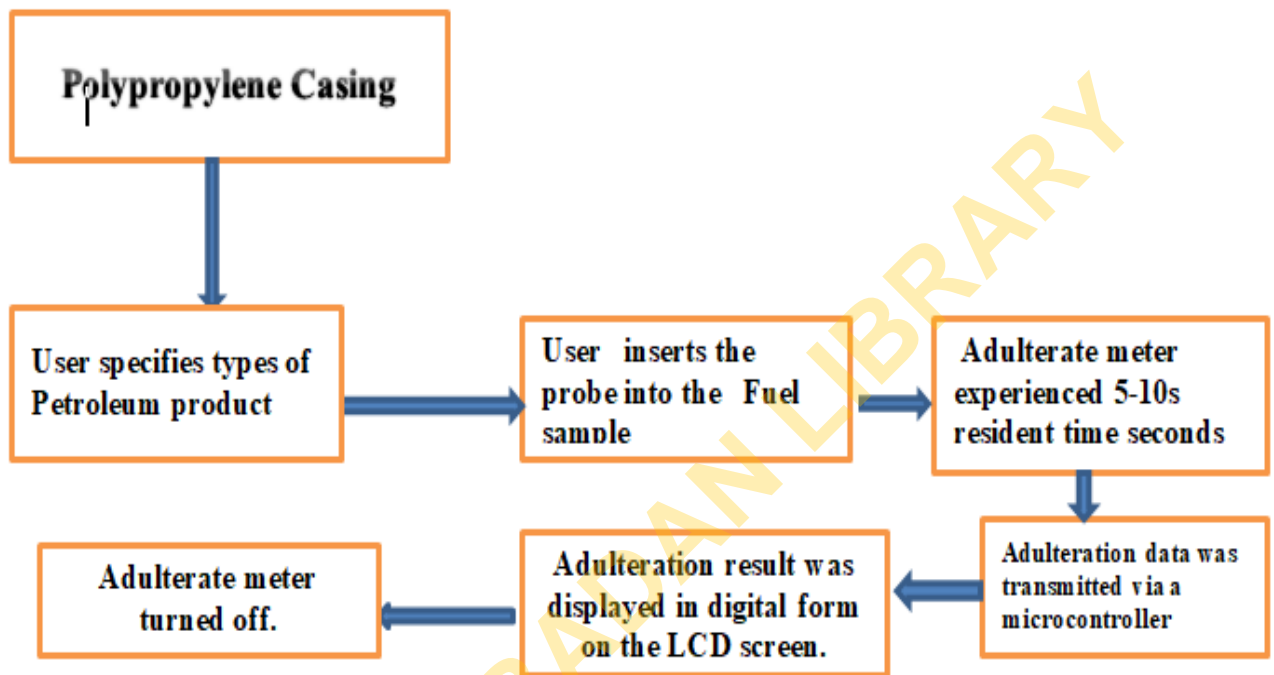

Figure 3.14: Design Block diagram of a specific gravity meter.

1. **The Casing:** The casing for the adulterate meter prototype employs a biodegradable polypropylene material, oval. The casing is aimed at maintaining the correct level of liquid to compare the specific gravity measurement. This technology offers several advantages over traditional plastic materials. Advantages of biodegradable materials are:
 - i. **Waste Reduction:** Biodegradable plastics may break down over several months, depending on the materials involved and their disposal conditions
 - ii. **Source Reduction**
 - iii. **Plastic-Eating Bacteria**

2. **The use of a Sensor :** It was used to measure the liquid's specific gravity. Its analogue output is connected to the microcontroller's analogue input. This sensor is designed with a load cell that measures the weight of a fixed volume of liquid. It compares it with the weight of the same volume of water to get the liquid's specific gravity. The calculation is done in the microcontrollers. The sensor gives both liquids' weight using a Hall effect sensor, along with a particular gravity meter probe (1000mm) that can travel and receive the adjusted specific gravity readings with a stainless tip.



Figure 3.8: Picture of the Sensor

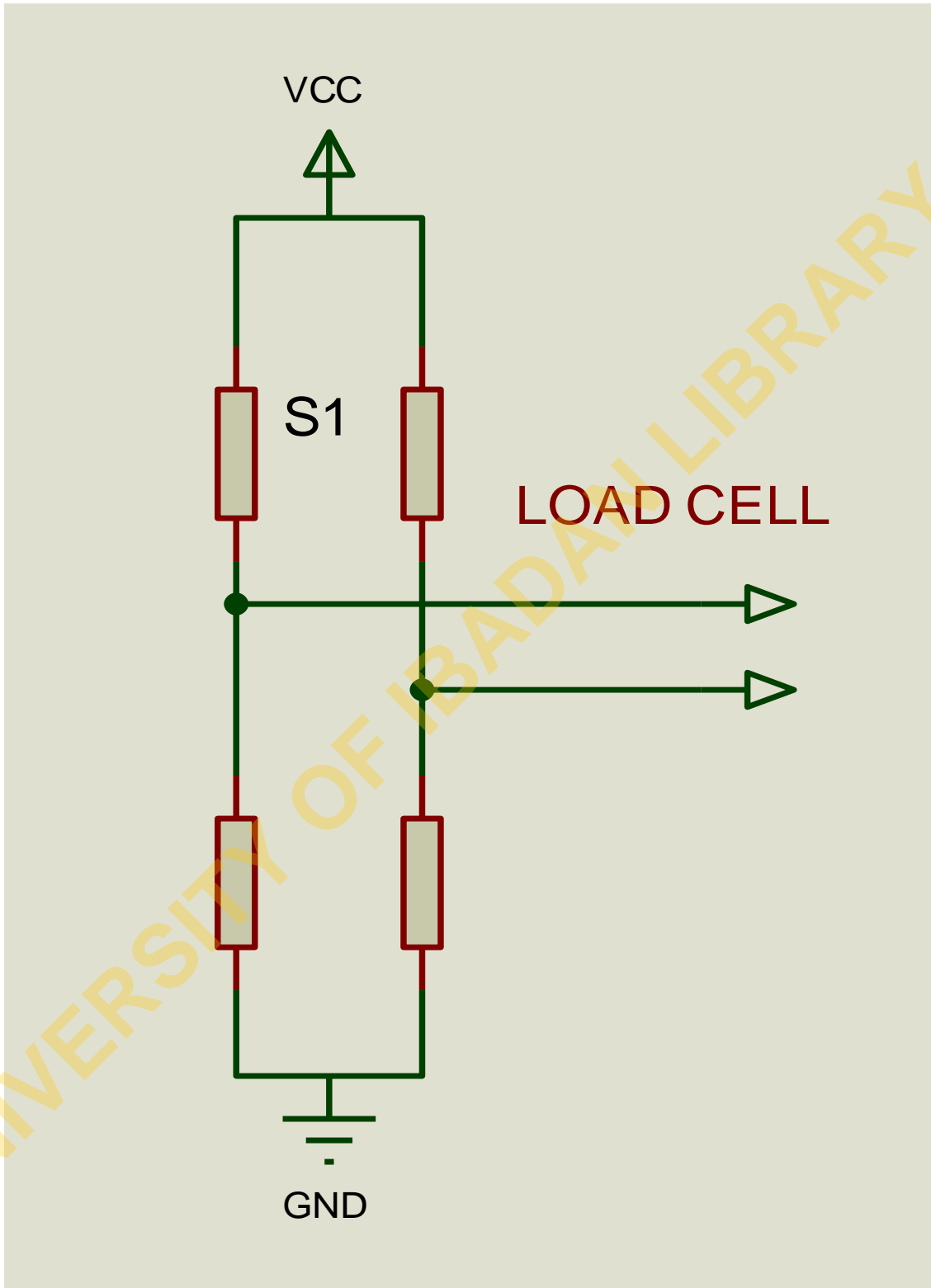

Figure 3.9: Circuit diagram of the sensor using a load cell

3. The Microcontroller: This is the heart of the entire circuit; it defines the device's functionality through the program installed in it. The microcontroller used is a PIC16f876 microchip device with multiple input/ output pins used to interface with LCD and analogue inputs used for reading sensor values. It has low power consumption and large program memory space. In this project, the program is written in assembly language and compiled with MPLAB, then transferred to the microchip device with a TOP2007 universal programmer. The microcontroller takes the reading of the weight of a liquid from the sensor. It compares it with the weight of the same volume of water pre-stored in the program to get the liquid's specific gravity. The result is converted and displayed on the LCD screen.



Figure 3.10: The picture of Microcontroller

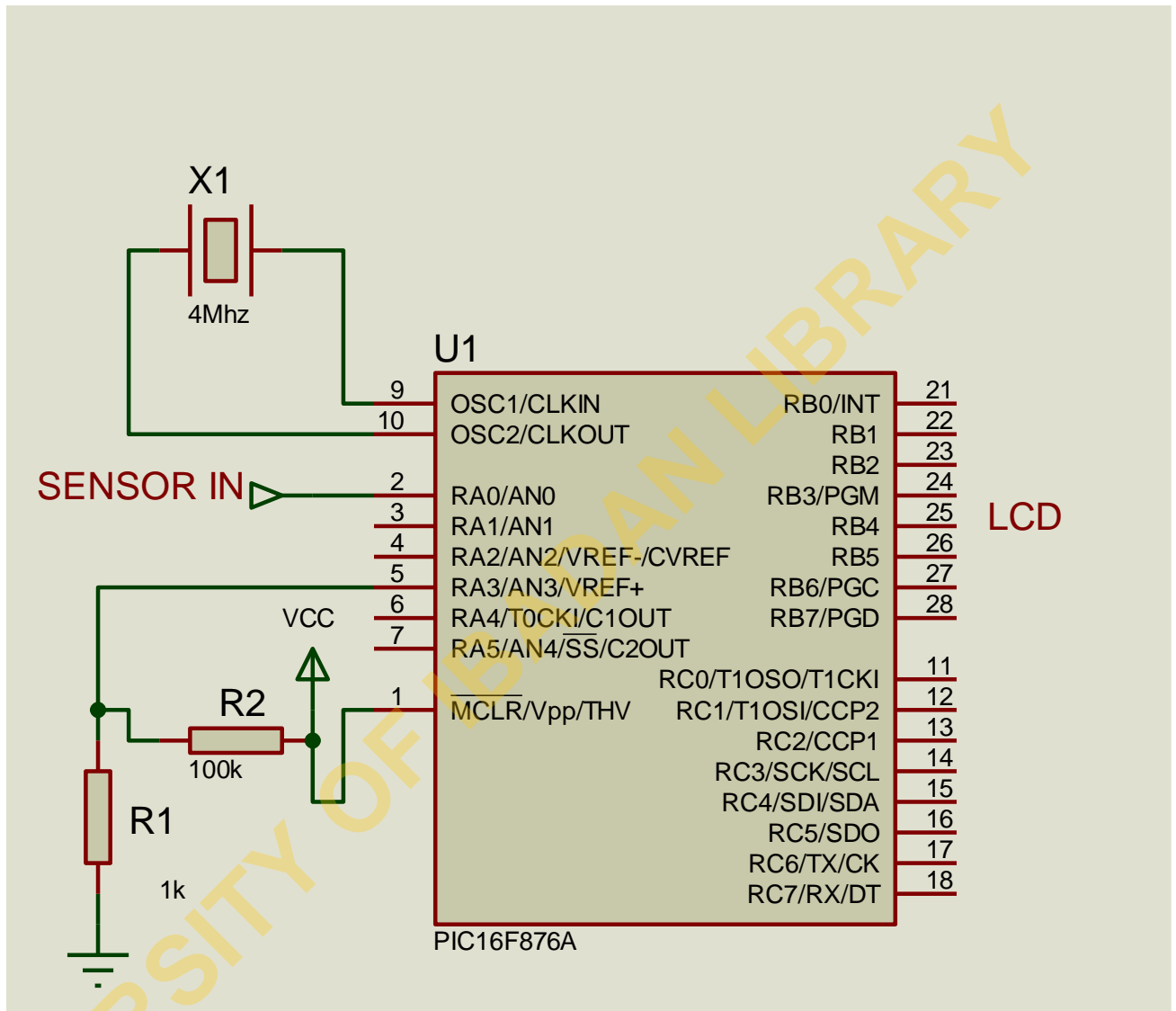

Figure 3.11: The circuit diagram of the microcontroller section

4. A liquid-crystal display (LCD): is a flat-panel display or another electronically modulated optical device that uses liquid crystals' light-modulating properties. Liquid crystals do not emit light directly. Instead, they use a backlight or reflector to produce images in colour or monochrome. The LCD screen receives information from the microcontroller and displays it. A 16 by 2 character display was used. It was interfaced with the microcontroller using a parallel mode since adding a serial converter will make the project consume more power.



Figure 3.12: The picture of LCD Screen

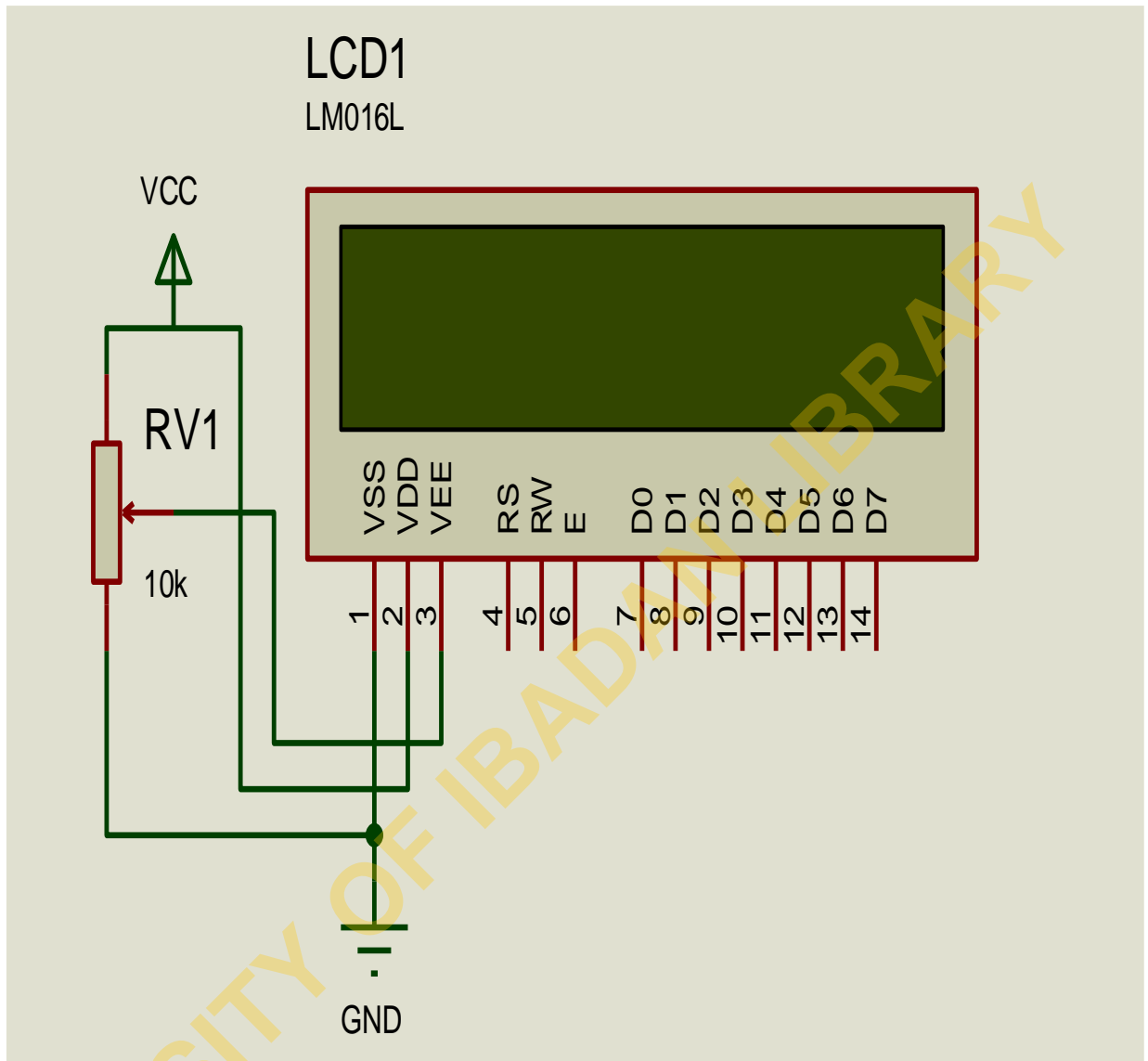

Figure 3.13: The LCD screen's circuit diagram (Resistor RV1 is used to adjust the display) contrast.

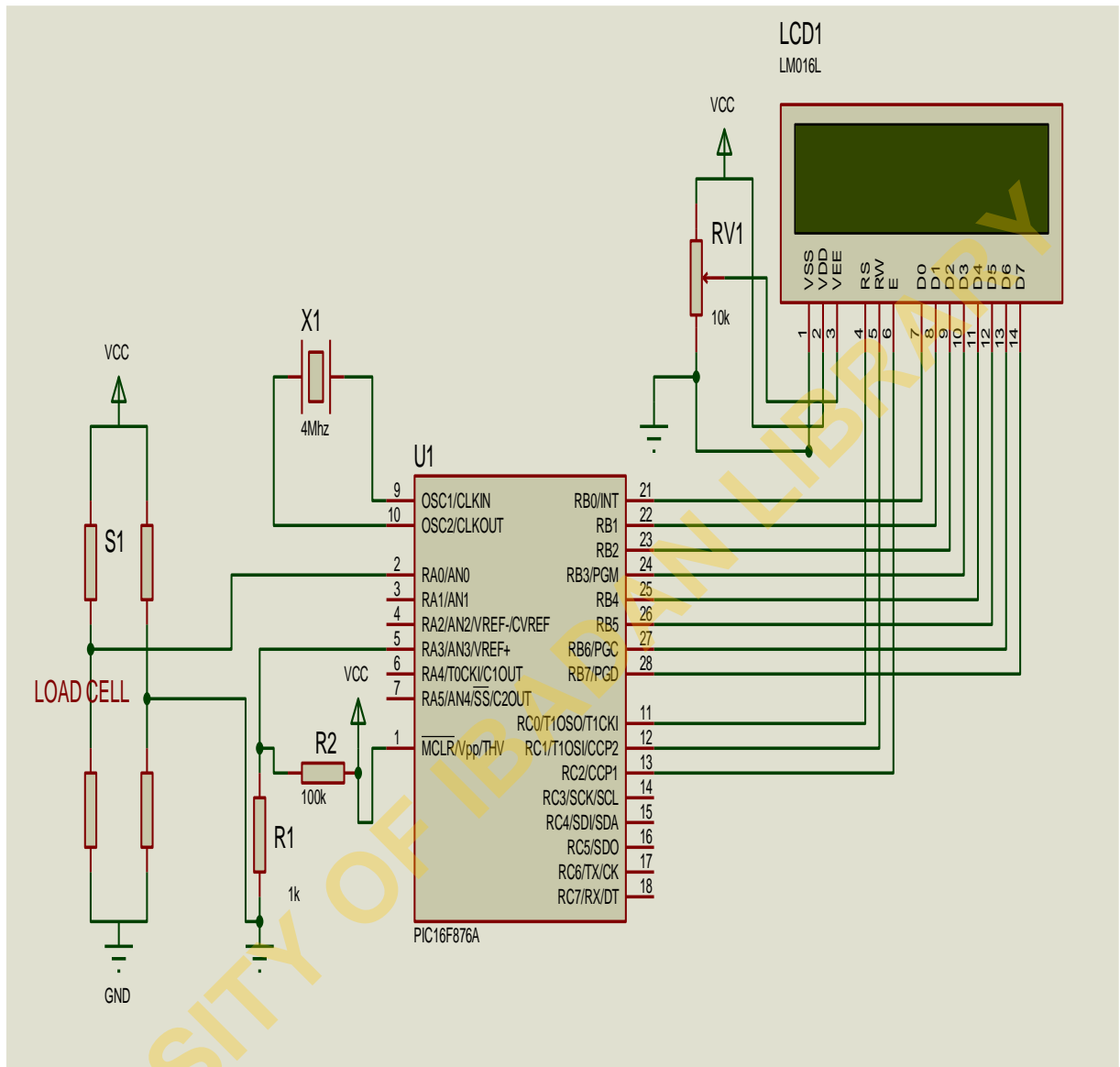

Figure 3.15: Circuit diagram of specific gravity meter with power supply.

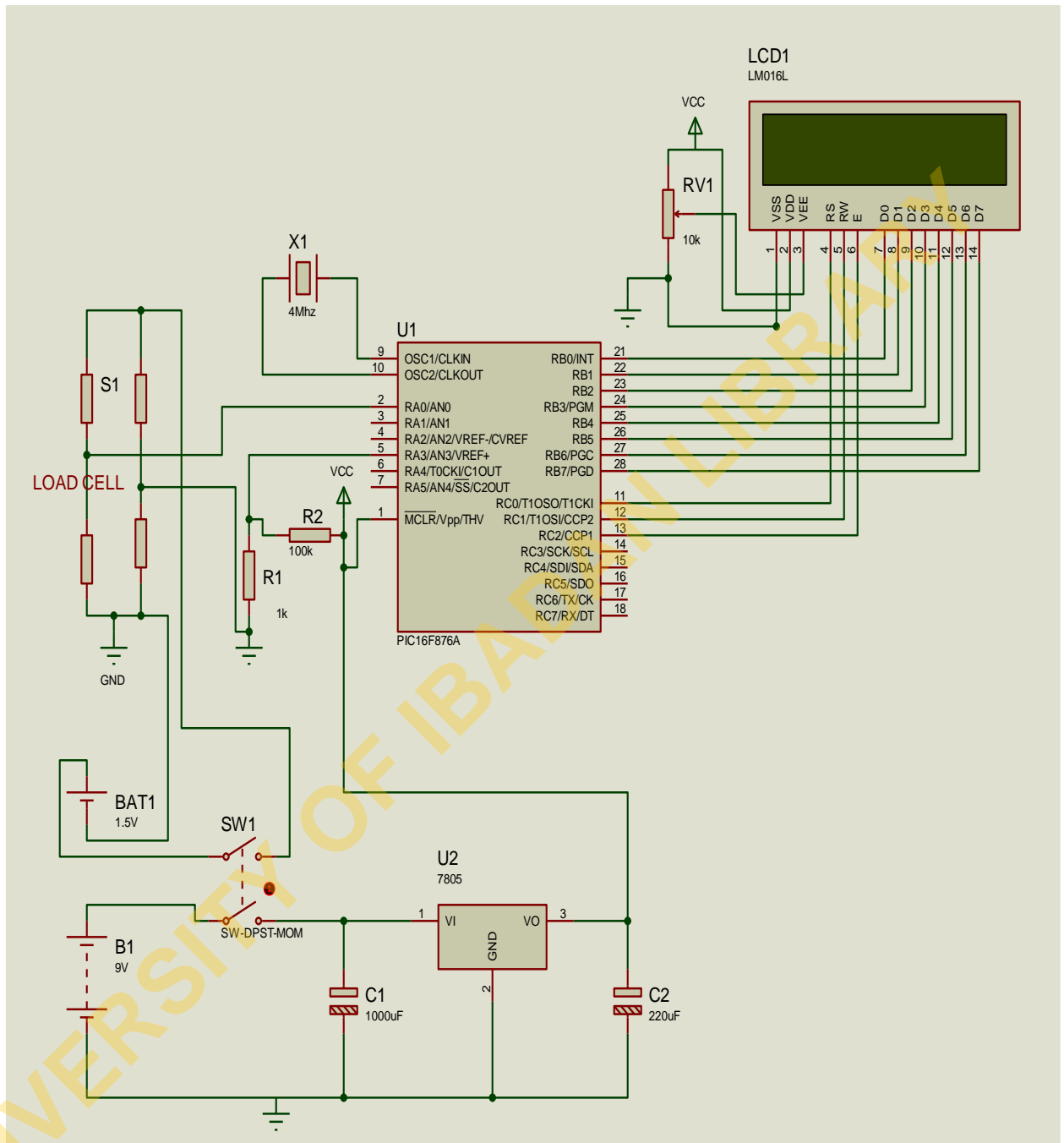

Figure 3.22. Circuit diagram of specific gravity meter with power supply and Load Cell

5. The Led: They are called light-emitting diodes, LED lamp is an electric light for use in light fixtures that produces light using one or more light-emitting diodes (LEDs). LED lamps have a lifecycle which is significantly many times longer than equivalent incandescent lamps and are significantly more efficient than most fluorescent lamps, with some LED chips able to emit up to 303 lumens per watt . However, LED lamps to require an electronic LED driver circuit when operated from mains power lines

3.8 Ergonomics of the design

In order to ensure the universal usability of this product, it is important to consider ergonomics in the design. A key consideration in this design is, therefore, the language of communication. The goal is to design a product that can be used regardless of what language the user speaks. Thus, the specific gravity meter will incorporate a set of universal colours (green, red) to indicate the meter's function or mode.

In addition, the design is simple, innovative, and intuitive so that it utilizes the smallest quantity of resources possible, reducing the cost of production while maintaining efficiency. Finally, and most importantly, it is safe with a tolerance of error built into the design to ensure safety regardless of use.

3.9 Design Simulation using Assembling Language.

Assembly language is a computer programming method that has its architectural machine code instructions and its program statement strongly related. Assembly language may also be called emblematic machine code. Assembly language usually has one statement per machine instruction. Still, assembler orders macros and symbolic labels of program and memory locations are often also sustained. This chip's program was carefully written and debugged adequately before hex files were burnt to the chip.

3.10 Design in 2 and 3 Dimensional AutoCAD Drawing of Developed Petroleum Products Adulteration Detector.

The designed petroleum products adulteration detector was named after what it does, detection of adulteration in fuel sample from any source. Thus the term adulterate-meter can be defined as a device that detects adulteration in fuel sample in real-time. There are control knobs on the device, light-emitting diodes all were embedded in the casing to indicate the degree of adulteration of the fuel sample. The device is represented in 2 and 3-Dimensional AutoCAD drawings.

3.10.1 Brief description of the Drawing:

1. The casing (biodegradable polyethylene structure): The casing for the adulterate meter prototype employs a biodegradable polypropylene material, oval with 40mm in diameter. The casing is aimed at maintaining the correct level of liquid to compare the specific gravity measurement. Plastics that can be decomposed by the action of living organisms are called biodegradable; as such they are user friendly basically because they are user friendly.
2. The use of a sensor - It was used to measure the liquid's specific gravity. Its analogue output is connected to the microcontroller's analogue input. The sensor is designed with a load cell that measures the weight of a fixed volume of liquid. Also, it can be compared with the same volume of water to get the liquid's specific gravity. The calculation is done in the microcontrollers. The sensor gives both liquids the weight using a hall effect sensor. A tightly wound, long specific gravity meter probe (1000mm) can travel and receive the adjusted specific gravity readings with a stainless tip.
3. The microcontroller – This is the heart of the entire circuit; it defines the device's functionality through the program installed in it. The microcontroller used is a PIC16f876 microchip device with multiple input/ output pins with multiple input/ output pins used to interface with LCD and analog inputs used for reading sensor values. It has low power consumption and large program memory space. In this project, the program is written in assembly language and compiled with MPLAB, then transferred to the microchip device with a TOP2007 universal programmer.

The microcontroller takes the reading of the weight of a liquid from the sensor. It compares it with the weight of the same volume of water pre-stored in the program to get the liquid's specific gravity. The result is converted and displayed.

4. The LCD: A liquid-crystal display (LCD) uses liquid crystals and light-modulating properties. LCD is a flat-panel display or another electronically modulated optical device system. Liquid crystals do not emit light directly, Instead, they use a backlight to produce images in monochrome. The LCD screen receives information from the microcontroller and displays it. A 16 by 2-character display was used. It was interfaced with the microcontroller using a parallel mode since adding a serial converter will make the project consume more power.
5. The LED: LED light bulb can be refers to a good semi- conductors which transmits light when current is allowed to flow through them. They are usually very small, with low power consumption. However, LED light is so concentrated and has high blue content, it can cause severe glare if not properly maintained. Blue light disseminates more in the human eye than the longer wavelengths of yellow and red, and sufficient levels can damage the human eye. LED lamps to require an electronic LED driver circuit when operated from mains power lines, the energy released are in form of photons.

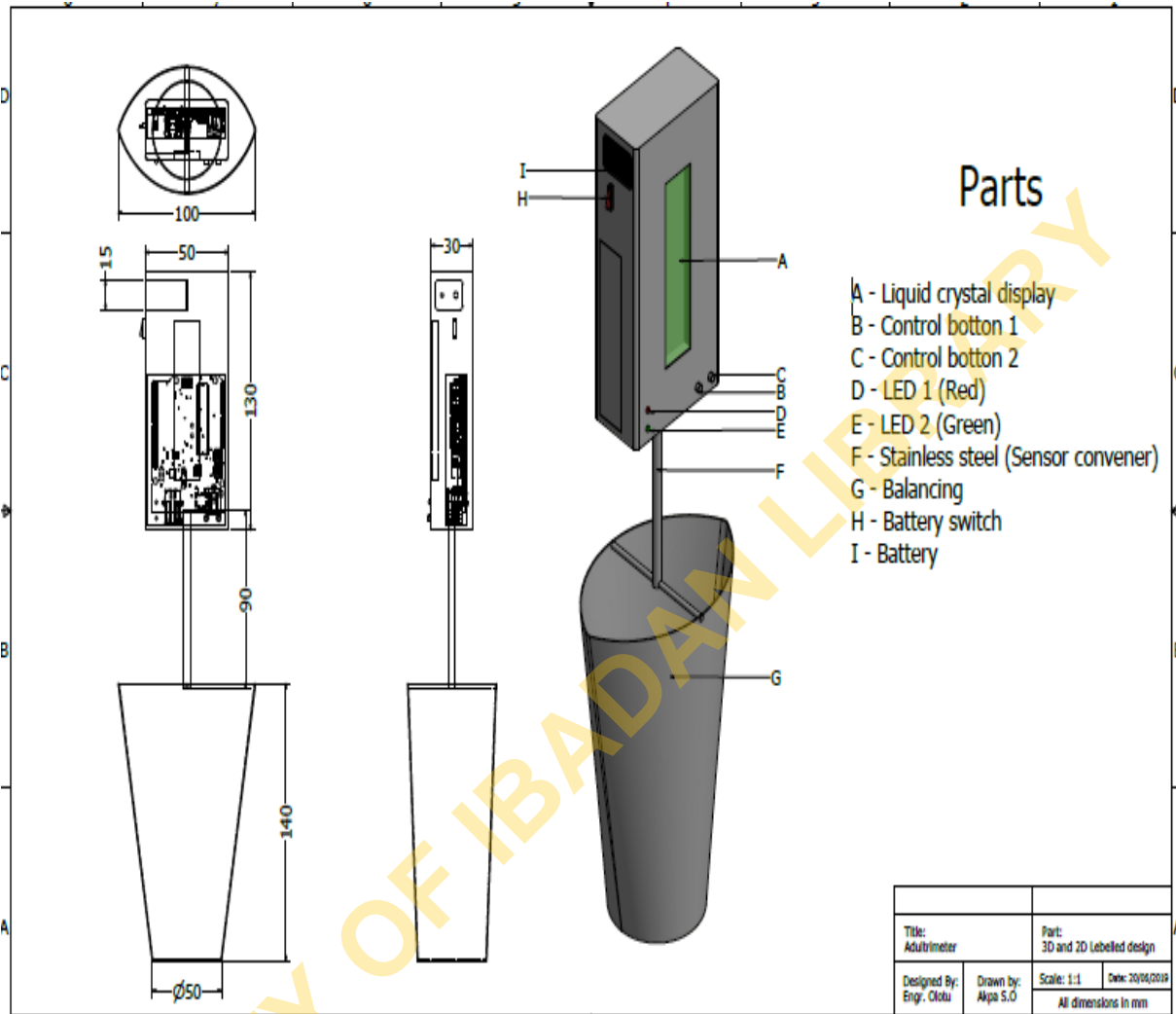

Figure 3.16: 2 and 3 Dimensional AUTOCAD Drawings

3.11 Adulterate Meter Performance Evaluation

Materials: 250ml measuring cylinder, Beakers, Adulterate- meter, Thermometer, Hydrometers, 250ml diesel, 250ml kerosene, 250ml petrol, 150ml water. 150ml naphtha, 150ml alcohol, 150ml lubricating oil, 150ml Healy oil, 100ml fuel oil,

Method: Adulterate meter were thoroughly washed with detergent, rinsed with water followed by distilled water, and were allowed to dry thoroughly. Petroleum product samples were prepared at ambient temperature; adulterated fuel samples were prepared as above. Adulterated sample was poured into the Adulterate meter for evaluation, till the sample torches the sensor (the tip) of the device and the specific gravity reading of each sample were recorded. The light emitting diode indicator on the Adulterate –meter were also noted.

3.9.1 Precautions

- Specific gravity meter was switched on before readings were recorded.
- It was assumed that all adulterants were extremely toxic.
- All readings were observed and compared to that of the literature.



Figure 3.17: Samples of Adulterant (A-Alcohol, B-Used Lubricating Grease, C- Fuel Oil)

UNIVERSITY OF IBADAN LIBRARY



Figure 3.18: Samples of Adulterant (D- Naphtha, E-Lubricating grease, F-Water)



Figure 3.19: Samples of Adulterant (G-Petrol, H-Kerosene, I-Diesel)



Figure 3.20: Adulterate - meter detecting Impurity in Diesel



Figure 3.21: Adulterate - meter detecting Impurity in Kerosene.

UNIVERSITY OF IBADAN LIBRARY



Figure 3.22: Adulterate meter with no sample

CHAPTER FOUR

RESULTS AND DISCUSSION

This chapter presents the result of the specific gravity of the experimental data, kay mixing rule data and Modified Kay mixing Rule (Tab 4.1 -4.7), Interfacial tension of the experimental data and that of Kay mixing rule data (Tab 4.7- 4.13), the developed Petroleum products adulteration detector called Adulterate meter evaluation results (Tab 4.14 -4.40), and then the statistical analysis obtained from all the models (4.45) all in a tabular form. Likewise, the chapter presents a comparative plots of the actual specific gravity meter readings with adulterate meter readings (Fig 4.2 - 4.30).

4.1 Specific Gravity Result.

Laboratory experiments and analysis of Fuel adulteration at different concentrations by volume and temperatures were compared with the result of Kay- mixing rule and also the modified kay mixing rule as developed in equation 3.6. It was also observed that the specific gravity as it varies with Temperature plays a vital role in detecting adulteration. The specific gravity increased with the increase in the volume of adulterant as the temperature reduces. The specific gravity obtained from the Kay mixing technique after the introduction of an adjustment factor has little or no difference with the actual measurement. However, the kay mixing rule obtained was not following an ideal pattern, hence the reason for the modification.

From Tables 4.3- 4.7 , The temperature became steady at 55%-75% by volume of adulteration ,additional quantity of adulterant had a marginal effect on the Temperature , hence the Temperature tends towards a reduction. The marginal effect of Temperature also reflected on the Specific gravity at the same level of adulterant for both the Modified and Actual Specific gravity and this is applicable to both Miscible and Immiscible system.

It can also be stated that, the liquid contaminant had significant effect on Fuel adulteration, the results of Naphtha, Lubricating oil, Industrial solvent and Diesel predicted that level of Adulteration were very well within the regulatory specifications of fuel even within 20% adulteration. On the contrary, the fuel oil shows strong evidence of fuel adulteration especially with diesel. It's also emerges out broadly from the outcomes of this study that monitoring adulteration of Diesel with Kerosene and Petrol can be very difficult up to about 50% level of adulteration.

Table 4.45 presented the statistical comparative studies of the Specific gravity obtained from the Experimental Result and the developed models(the Kay's mixing rule and the Mathematical model using the standard deviation approach, this is the percentage deviation of the Model result to the true value which is the experimental result.

Table 4.1: Specific gravity result of Petrol: kerosene system.

S/N	Temp °C	Petrol Kerosene Proportion% (v/v).	Kay mixing rule (SG)	Modified Kay mixing rule(SG)	Actual specific gravity
1	28	100:0	0.893	0.835	0.833
2	27	95:05	0.889	0.851	0.853
3	26	85:15	0.882	0.864	0.865
4	25	75:25	0.875	0.868	0.868
5	24	65:35	0.867	0.879	0.875
6	26	55:45	0.860	0.888	0.888
7	25	45:55	0.853	0.894	0.892
8	25	35: 65	0.846	0.895	0.893
9	24	25:75	0.838	0.889	0.880
10	24	15:85	0.831	0.881	0.880
11	23	05:95	0.824	0.890	0.890
12	23	0:100	0.820	1.000	1.000

Table 4.2: Specific gravity result of Petrol: Diesel system.

S/N	Temp °C	Petrol Kerosene Proportion% (v/v).	Kay mixing rule(SG)	Modified Mixing rule SG	KayActual specific gravity
	28	100:0	0.893	0.835	0.823
2	27	95:05	0.888	0.850	0.850
3	26	85:15	0.872	0.864	0.864
4	25	75:25	0.870	0.868	0.868
5	24	65:35	0.867	0.879	0.875
6	26	55:45	0.856	0.883	0.886
7	25	45:55	0.853	0.894	0.891
8	25	35: 65	0.826	0.875	0.863
9	24	25:75	0.838	0.889	0.880
10	24	15:85	0.820	0.871	0.870
11	23	05:95	0.823	0.890	0.886
12	23	0:100	0.820	1.000	1.000

Table 4.3: Specific gravity result of Petrol: Water System.

S/N	Temp °C	Petrol Kerosene Proportion% (v/v).	Kay Mixing Rule SG	Modified Kay Mixing Rule SG	Actual specific gravity
1	28	100:0	0.893	0.835	0.835
2	27	95:05	0.889	0.851	0.851
3	26	85:15	0.882	0.864	0.864
4	25	75:25	0.920	0.868	0.868
5	24	65:35	0.930	0.879	0.879
6	26	55:45	0.941	0.888	0.888
7	25	45:55	0.952	0.894	0.893
8	25	35: 65	0.963	0.895	0.894
9	24	25:75	0.973	0.889	0.888
10	24	15:85	0.984	0.881	0.880
11	23	05:95	0.995	0.890	0.890
12	23	0:100	0.100	1.000	1.000

Table 4.4: Specific gravity of Petrol: Lubricating oil system.

S/N	Temp °C	Petrol Kerosene Proportion% (v/v).	Kay mixing rule SG	Modified Kay Mixing rule SG	Actual specific gravity
1	28	100:0	0.893	0.835	0.833
2	27	95:05	0.889	0.851	0.853
3	26	85:15	0.882	0.864	0.865
4	25	75:25	0.875	0.868	0.868
5	24	65:35	0.867	0.879	0.875
6	26	55:45	0.860	0.888	0.888
7	25	45:55	0.853	0.894	0.892
8	25	35: 65	0.846	0.895	0.893
9	24	25:75	0.838	0.889	0.880
10	24	15:85	0.831	0.881	0.880
11	23	05:95	0.824	0.890	0.890
12	23	0:100	0.820	1.000	1.000

Table 4.5: Specific gravity result of Petrol: Naphtha system.

S/N	Temp °C	Petrol Kerosene Proportion% (v/v).	Kay Mixing SG	Modified Mixing SG	Kay Actual gravity.	specific
1	28	100:0	0.893	0.835	0.833	
2	27	95:05	0.889	0.851	0.853	
3	26	85:15	0.882	0.864	0.865	
4	25	75:25	0.875	0.868	0.868	
5	24	65:35	0.867	0.879	0.875	
6	26	55:45	0.860	0.888	0.888	
7	25	45:55	0.853	0.894	0.892	
8	25	35: 65	0.846	0.895	0.893	
9	24	25:75	0.838	0.889	0.880	
10	24	15:85	0.831	0.881	0.880	
11	23	05:95	0.824	0.890	0.890	
12	23	0:100	0.820	1.000	1.000	

Table 4.6: Specific gravity result of Petrol: Industrial solvent system

S/N	Temp °C	Petrol Kerosene Proportion% (v/v).	Kay mixing rule SG	Modified mixing rule SG	Kay Actual gravity	specific
1	28	100:0	0.893	0.835	0.833	
2	27	95:05	0.889	0.851	0.853	
3	26	85:15	0.882	0.864	0.865	
4	25	75:25	0.875	0.868	0.868	
5	24	65:35	0.867	0.879	0.875	
6	26	55:45	0.860	0.888	0.888	
7	25	45:55	0.853	0.894	0.892	
8	25	35: 65	0.846	0.895	0.893	
9	24	25:75	0.838	0.889	0.880	
10	24	15:85	0.831	0.881	0.880	
11	23	05:95	0.824	0.890	0.890	
12	23	0:100	0.820	1.000	1.000	

Table 4.7: Specific gravity result using of Petrol: Fuel oil system .

S/N	Temp °C	Petrol Kerosene Proportion% (v/v).	Kay mixing rule SG	Modified mixing rule SG	KayActual gravity.	specific
1	28	100:0	0.893	0.835	0.833	
2	27	95:05	0.889	0.851	0.853	
3	26	85:15	0.882	0.864	0.865	
4	25	75:25	0.875	0.868	0.868	
5	24	65:35	0.867	0.879	0.875	
6	26	55:45	0.860	0.888	0.888	
7	25	45:55	0.853	0.894	0.892	
8	25	35: 65	0.846	0.895	0.893	
9	24	25:75	0.838	0.889	0.880	
10	24	15:85	0.831	0.881	0.880	
11	23	05:95	0.824	0.890	0.890	
12	23	0:100	0.820	1.000	1.000	

4.2 Interfacial Tension Result Obtained from Mixing Rule.

Table 4.7 - 4.13 shows the fuel adulteration at different concentrations by volume and at ambient temperatures using kay- mixing rule and then the modified kay-mixing rule technique and the result compared with the actual experimental readings. It was observed that the interfacial tension varies with level of adulteration by volume vital role in detecting adulteration. Likewise, the increase with the increase in the volume of adulterant at ambient temperature, the interfacial tension obtained from the kay's mixing technique has little or no difference with the actual measurement especially after the introduction of the adjustment factor. However, the kay mixing rule obtained was not following an ideal pattern, hence the reason for the modification from Equation 3.7.

From Tables 4.7- 4.17, Adulteration of Petroleum sample was detected at 20-30% by volume of contamination, but at 40%-70% by volume of adulteration, additional quantity of adulterant had a marginal effect on the Interfacial Tension. The marginal effect of ITF also reflected at the same level of adulterant for both the Modified and Actual Interfacial Tension, which is applicable to both Miscible and Immiscible system.

Table 4.7: Interfacial Tension (IFT) result of Petrol : Kerosene system .

S/N	Petrol Kerosene Proportion% (v/v)	Kay Mixing Rule IFT	Modified Kay Mixing Rule IFT	Actual IFT
1	100:0	28.0	47.8	48.0
2	80:20	28.4	48.4	44.6
3	60:40	28.8	40.4	40.2
4	40:60	29.2	40.8	40.0
5	50:50	29.0	38.0	37.0
6	60:40	32.8	35.4	35.7
7	80:20	29.6	27.2	27.5
8	0: 100	30.0	25.6	25.0

Table 4.8: Interfacial tension of Petrol : Diesel system.

S/N	Petrol Diesel Proportion% (v/v)	Kay mixing Rule IFT	Modified Kay mixing Rule IFT	Actual ITF
1	100:0	28.0	47.8	48.0
2	80:20	27.6	48.4	48.6
3	60:40	27.2	48.4	46.2
4	40:60	26.8	42.8	42.0
5	50:50	32.0	37.0	37.0
6	60:40	37.6	35.4	35.7
7	80:20	31.6	29.2	29.5
8	0: 100	26.0	25.6	25.0

Table 4.9: Interfacial tension result using Kay mixing rule of Petrol: Water system.

SN	Petrol Water Proportion% (v/v)	Kay Mixing	Modified Kay Mixing Rule(IFT	Actual ITF
1	100:0	28.0	47.8	48.0
2	80:20	28.4	48.4	44.6
3	60:40	28.8	40.4	40.2
4	40:60	29.2	40.8	40.0
5	50:50	29.0	38.0	37.0
6	60:40	32.8	35.4	35.7
7	80:20	29.6	27.2	27.5
8	0: 100	30.0	25.6	25.0

Table 4.10: Interfacial tension result of Petrol: Lubricating oil system.

S/N	Petrol Kerosene Proportion% (v/v)	Kay Mixing Rule IFT	Modified Kay Mixing Rule (IFT)	Actual ITF
1	100:0	28.0	47.8	48.0
2	80:20	27.4	44.4	44.6
3	60:40	26.8	42.4	42.4
4	40:60	26.2	41.8	41.0
5	50:50	26.5	42.0	42.0
6	60:40	36.8	36.4	36.7
7	80:20	25.6	26.2	27.5
8	0: 100	25.0	25.6	26.6

Table 4.11: Interfacial tension of Petrol: Naphtha system.

S/N	Petrol Kerosene Proportion% (v/v)	Kay Rule	Mixing IFT	Modified Mixing Rule	Actual IFT
1	100:0	28.0		47.8	47.0
2	80:20	27.0		48.4	48.6
3	60:40	25.6		40.4	40.2
4	40:60	24.4		40.8	40.8
5	50:50	24.0		38.0	38.0
6	60:40	26.4		35.4	35.4
7	80:20	10.0		27.2	27.2
8	0: 100	23.0		25.6	25.6

Table 4.12: Interfacial tension result using Kay mixing rule of Petrol: Alcohol system

S/N	Petrol Proportion% (v/v)	Alcohol	Kay mixing rule IFT	Modified Kay mixing rule IFT	Actual ITF
1	100:0		28.0	46.8	46.0
2	80:20		27.4	44.4	44.6
3	60:40		26.8	42.4	42.2
4	40:60		26.2	42.8	42.0
5	50:50		39.0	48.0	47.0
6	60:40		26.8	46.4	46.7
7	80:20		10.6	20.2	20.5
8	0: 100		25.0	26.6	26.0

Table 4.13: Interfacial tension result of Petrol: Fuel oil system.

S/N	Petrol Fuel oil Proportion% (v/v)	Kay Rule	Mixing IFT	Kay IFT	Mixing IFT	Rule Actual ITF
1	100:0	28.0		47.8		48.0
2	80:20	28.4		48.4		44.6
3	60:40	28.8		40.4		40.2
4	40:60	29.2		40.8		40.0
5	50:50	29.0		38.0		37.0
6	60:40	32.8		35.4		35.7
7	80:20	29.6		27.2		27.5
8	0: 100	30.0		25.6		25.0

4.3 Adulterate Meter Evaluation Results.

The developed adulterate meter was tested. Adulterated fuel samples were prepared by varying the concentration of each sample with a known quantity of an adulterant. Table 4.14- 4.34, show the tabular results obtained, where Figure 4.2- 4.30 show the graphical plots of actual specific gravity readings and the adulterate meter readings against temperature for both liquid and solid contaminants. The table also presented the result of the developed mathematical model in Equation 3.5 Olotu, *et al* (2018) which detected adulteration in real-time of 25 -35% by volume of Adulteration. Meanwhile as presented by Fadairo et al,(2020), who developed a filter/litmus paper for adulteration detection, however, his work did not detect adulteration in real time. Likewise in accordance to the work of Olanisebe et al, (2013) that the use of water cut meter especially when fuel is adulterated with water in a reservoir is achievable, rather, the development of an Adulterate meter also detect Adulteration in Fuel: water system, hence serves as a perfect substitute to water cut meter. The lines obtained show that the specific gravity of the sample increases with increase in temperature. These results explained the general effect of the temperature on specific gravity of adulterated hydrocarbon sample. The new adulterate meter readings and the actual readings majorly, has no significant difference. This design also compensate for temperature variation.

Tab 4.14 -4.19, The temperature became steady at 45%-95% by volume of adulteration, additional quantity of adulterant had a marginal effect on the Temperature, hence the Temperature tends towards a reduction. The marginal effect of Temperature also reflected on the Specific gravity at the same level of adulterant for Modelled Specific gravity, Adulterate meter readings and Actual Specific gravity readings and this is applicable to both Miscible and Immiscible system.

Table 4.14: Adulterate meter evaluation result using Petrol: Water mixed system.

S/N	Temp °C	Petrol and water Proportion% (v/v)	Modelled Gravity.	Specific Adulterate reading g/cm ³	meter Actual gravity g/cm ³	Specific
1	28	100:0	0.812	0.812	0.812	
2	27	95:05	0.816	0.816	0.816	
3	26	85:15	0.824	0.824	0.827	
4	25	75:25	0.837	0.837	0.839	
5	24	65:35	0.845	0.845	0.844	
6	26	55:45	0.855	0.855	0.851	
7	25	45:55	0.856	0.856	0.856	
8	25	35: 65	0.857	0.857	0.854	
9	24	25:75	0.858	0.858	0.860	
10	24	15:85	0.860	0.860	0.860	
11	23	05:95	0.861	0.861	0.861	
12	23	0:100	1.000	1.000	1.000	

Table 4.15: Adulterate meter evaluation result using Kerosene: Water system.

S/N	Temp °C	Kerosene water Proportion% (v/v)	and Modelled Gravity.	Specific Adulterate meter reading	Actual specific gravity
1	31	100:0	0.815	0.810	0.810
2	30	95:05	0.820	0.813	0.811
3	31	85:15	0.857	0.815	0.812
4	29	75:25	0.877	0.820	0.816
5	28	65:35	0.875	0.843	0.825
6	27	55:45	0.835	0.852	0.838
7	25	45:55	0.889	0.883	0.878
8	25	35: 65	0.890	0.894	0.879
9	24	25:75	0.950	0.896	0.890
10	24	15:85	0.949	0.897	0.927
11	25	05:95	0.975	0.890	0.947
12	24	0:100	1.000	1.000	1.000

Table 4.16: Adulterate meter evaluation result using Diesel: Water system.

S/N	Temp °C	Diesel and water Proportion%(v/v)	Modelled Specific Gravity.	Adulterate meter reading	Actual specific gravity
1	31	100:0	0.948	0.948	0.830
2	30	95:05	0.950	0.949	0.840
3	28	85:15	0.960	0.950	0.850
4	27	75:25	0.963	0.960	0.860
5	25	65:35	0.972	0.963	0.878
6	22	55:45	0.981	0.964	0.879
7	23	45:55	0.982	0.965	0.900
8	23	35: 65	0.984	0.975	0.916
9	22	25:75	0.985	0.985	0.923
10	23	15:85	0.986	0.995	0.965
11	22	05:95	0.987	0.998	0.983
12	22	0:100	1.000	1.000	1.000

Table 4.17: Adulterate meter evaluation result using binary mixture of Petrol: Diesel system

S/N	Temp °C	Petrol and Diesel Proportion% (v/v)	Modelled Gravity	Specific Adulterate meter reading	Actual specific gravity
1	23	100:0	0.843	0.833	0.830
2	23	95:05	0.909	0.853	0.853
3	23	85:15	0.911	0.848	0.863
4	23	75:25	0.931	0.878	0.878
5	24	65:35	0.945	0.889	0.898
6	26	55:45	0.948	0.885	0.899
7	28	45:55	0.950	0.882	0.930
8	28	35: 65	0.953	0.889	0.957
9	27	25:75	0.955	0.890	0.960
10	27	15:85	0.976	0.897	0.986
11	26	05:95	0.960	0.901	0.994
12	25	0:100	0.956	0.903	0.993

Table 4.18: Adulterate meter evaluation result using Petrol: kerosene system.

S/N	Temp °C	Petrol/ Kerosene Proportion% (v/v)	Modelled Specific Gravity.	Adulterate meter reading	Actual specific gravity
1	24	100:0	0.843	0.833	0.833
2	25	95:05	0.909	0.833	0.853
3	26	85:15	0.911	0.855	0.865
4	26	75:25	0.931	0.855	0.868
5	23	65:35	0.945	0.862	0.875
6	26	55:45	0.948	0.871	0.888
7	27	45:55	0.950	0.882	0.892
8	27	35: 65	0.953	0.883	0.893
9	26	25:75	0.955	0.884	0.880
10	25	15:85	0.976	0.886	0.880
11	26	05:95	0.960	0.887	0.890
12	25	0:100	0.956	0.888	1.000

Table 4.19: Adulterate meter evaluation result using Diesel: Kerosene system.

S/N	Temp °C	Diesel/kerosene Proportion% (v/v)	Modelled Gravity/cm ³ .	Specific Adulterate meter reading.	Actual specific gravity
1	25	100:0	0.830	0.811	0.830
2	25	95:05	0.975	0.817	0.830
3	24	85:15	0.981	0.825	0.828
4	23	75:25	1.089	0.837	0.827
5	23	65:35	1.097	0.845	0.826
6	23	55:45	1.099	0.842	0.825
7	23	45:55	1.095	0.855	0.827
8	24	35:65	1.006	0.856	0.887
9	24	25:75	1.003	0.857	0.897
10	25	15:85	1.001	0.858	0.849
11	25	05:95	0.975	0.850	0.810
12	25	0:100	0.965	0.831	1.000

4.4 Fuel Contaminated with Naphtha

Table 4.20: Shows the Adulterate meter evaluation result using Petrol: Naphtha mixed system.

S/N	Temp °C	Petrol/Naphtha Proportion% (v/v)	Modelled Specific Gravity.	Adulterate meter reading .	Actual specific gravity.
1	25	100:0	0.843	0.831	0.843
2	25	95:05	0.909	0.833	0.833
3	24	85:15	0.911	0.843	0.841
4	23	75:25	0.945	0.884	0.882
5	23	65:35	0.948	0.925	0.922
6	23	55:45	0.950	0.941	0.940
7	23	45:55	0.953	0.965	0.950
8	24	35: 65	0.955	0.964	0.961
9	24	25:75	0.965	0.967	0.966
10	25	15:85	0.960	0.943	0.945
11	25	05:95	0.963	0.952	0.952
12	25	0:100	0.965	0.965	0.975

Table 4.21: Adulterate meter evaluation result using Diesel: Naphtha system.

S/N	Temp °C	Diesel/Naphtha` Proportion% (v/v)	Modelled Gravity.	Specific Adulterate-meter reading.	Actual specific gravity.
1	25	100:0	0.830	0.811	0.812
2	25	95:05	0.975	0.817	0.817
3	24	85:15	0.981	0.825	0.825
4	23	75:25	1.989	0.837	0.839
5	23	65:35	1.997	0.845	0.844
6	23	55:45	1.999	0.842	0.842
7	23	45:55	1.995	0.855	0.856
8	24	35: 65	1.006	0.956	0.956
9	24	25:75	1.003	0.957	0.957
10	25	15:85	1.001	0.958	0.958
11	25	05:95	0.975	0.945	0.948
12	25	0:100	0.965	0.932	0.932

**Table 4.22: Adulterate meter evaluation result using binary mixture of Kerosene:
Naphtha system.**

S/N	Temp °C	Kerosene /Naphtha Proportion% (v/v)	Modelled Gravity	Specific Adulterate meter reading.	Actual specific gravity.
1	25	100:0	0.830	0.811	0.812
2	25	95:05	0.975	0.817	0.821
3	24	85:15	0.981	0.825	0.823
4	23	75:25	1.989	0.837	0.836
5	23	65:35	1.997	0.945	0.945
6	23	55:45	1.999	0.942	0.943
7	23	45:55	1.995	0.955	0.955
8	24	35: 65	1.006	0.956	0.956
9	24	25:75	1.003	0.957	0.957
10	25	15:85	1.001	0.958	0.958
11	25	05:95	0.975	0.956	0.959
12	25	0:100	0.965	0.958	0.959

4.5 Fuel Contaminated with Lubricating Oil.

Table 4.23: Adulterate meter evaluation result using Petrol: Lubricating oil system.

S/N	Temp °C	Petrol/Lubricating oil Proportion% (v/v)	Modelled Specific Gravity.	Adulterate meter reading.	Experimental specific gravity.
1	25	100:0	0.830	0.883	0.883
2	25	95:05	0.875	0.865	0.866
3	24	85:15	0.881	0.825	0.824
4	23	75:25	0.989	0.924	0.858
5	23	65:35	0.997	0.912	0.878
6	23	55:45	0.999	0.910	0.888
7	23	45:55	0.995	0.903	0.898
8	24	35:65	1.006	0.907	0.907
9	24	25:75	1.003	0.923	0.923
10	25	15:85	1.001	0.924	0.924
11	25	05:95	0.975	0.954	0.935
12	25	0:100	0.965	0.925	0.936

Table 4.24: Adulterate meter evaluation result using Diesel: Lubricating oil system.

S/N	Temp °C	Diesel / Lubricating oil Proportion% (v/v)	Modelled Specific Gravity/cm ³	Adulterate meter reading g/cm ³	Actual specific gravity g/cm ³
1	25	100:0	0.830	0.811	0.812
2	25	95:05	0.9875	0.817	0.816
3	24	85:15	0.881	0.825	0.824
4	23	75:25	0.989	0.837	0.837
5	23	65:35	0.997	1.845	0.845
6	23	55:45	1.899	1.842	0.855
7	23	45:55	1.895	1.855	0.856
8	24	35: 65	1.806	1.856	0.857
9	24	25:75	1.803	1.857	0.858
10	25	15:85	1.901	1.858	0.880
11	25	05:95	0.975	1.850	0.861
12	25	0:100	0.965	1.831	0.866

Table 4.25: Adulterate meter evaluation result using Kerosene: Lubricating oil system.

S/N	Temp °C	Kerosene/ Lubricating oil Proportion% (v/v)	Modelled Specific Gravity.	Specific Adulterate meter reading.	Actual specific gravity
1	25	100:0	0.830	0.816	0.816
2	25	95:05	0.975	0.817	0.817
3	24	85:15	0.981	0.825	0.825
4	23	75:25	0.989	0.837	0.833
5	23	65:35	0.997	0.845	0.840
6	23	55:45	0.999	0.842	0.841
7	23	45:55	0.995	0.958	0.849
8	24	35: 65	0.996	0.956	0.854
9	24	25:75	0.993	0.957	0.860
10	25	15:85	0.991	0.958	0.857
11	25	05:95	0.975	0.955	0.954
12	25	0:100	0.965	0.912	0.911

Table 4.26: Adulterate meter evaluation result using Petrol: Fuel Oil system.

S/N	Temp °C	Petrol/Fuel Oil Proportion% (v/v)	Modelled Gravity	Specific Adulterate meter reading	Actual specific gravity.
1	25	100:0	0.830	0.815	0.815
2	25	95:05	0.975	0.817	0.817
3	24	85:15	0.981	0.823	0.823
4	23	75:25	0.989	0.812	0.812
5	23	65:35	0.967	0.825	0.825
6	23	55:45	0.979	0.822	0.822
7	23	45:55	0.905	0.815	0.815
8	24	35: 65	0.906	0.806	0.806
9	24	25:75	0.903	0.807	0.807
10	25	15:85	0.901	0.808	0.808
11	25	05:95	0.915	0.807	0.807
12	25	0:100	0.945	0.805	0.805

Table 4.27: Adulterate meter evaluation result using binary mixture of Diesel: Fuel oil system.

S/N	Temp °C	Diesel/Fuel oil Proportion% (v/v)	Modelled Gravity.	Specific Adulterate meter reading.	Actual specific gravity
1	25	100:0	0.830	0.821	0.825
2	25	95:05	0.975	0.826	0.826
3	24	85:15	0.981	0.825	0.827
4	23	75:25	0.989	0.837	0.830
5	23	65:35	0.997	0.845	0.837
6	23	55:45	0.999	0.846	0.845
7	23	45:55	1.005	0.837	0.846
8	24	35: 65	1.006	0.838	0.848
9	24	25:75	1.003	0.839	0.850
10	25	15:85	1.001	0.866	0.868
11	25	05:95	0.975	0.879	0.875
12	25	0:100	0.965	0.805	0.865

Table 4.28: Adulterate meter evaluation result using Kerosene: Fuel oil system.

S/N	Temp °C	Kerosene/Fuel Oil Proportion% (v/v)	Modelled Gravity.	Specific Adulterate meter reading.	Actual specific gravity .
1	25	100:0	0.803	0.808	0.808
2	25	95:05	0.975	0.818	0.818
3	24	85:15	0.981	0.827	0.827
4	23	75:25	0.989	0.837	0.839
5	23	65:35	0.997	0.845	0.845
6	23	55:45	0.999	0.844	0.844
7	23	45:55	0.995	0.855	0.855
8	24	35: 65	1.006	0.856	0.854
9	24	25:75	1.003	0.857	0.860
10	25	15:85	1.001	0.859	0.860
11	25	05:95	0.975	0.851	0.850
12	25	0:100	0.965	0.841	0.840

4.6 Fuel Contaminated with Industrial Solvent (Alcohol).

Table 4.29: Adulterate meter evaluation result using Petrol: Alcohol system

S/N	Temp °C	Petrol/Alcohol Proportion% (v/v)	Modelled Gravity	Specific Adulterate meter reading	Actual specific gravity
1	25	100:0	0.830	0.801	0.802
2	25	95:05	0.805	0.807	0.806
3	25	85:15	0.811	0.805	0.805
4	25	75:25	0.803	0.807	0.807
5	23	65:35	0.807	0.805	0.809
6	23	55:45	0.809	0.802	0.802
7	23	45:55	0.806	0.805	0.805
8	24	35:65	0.803	0.806	0.806
9	24	25:75	0.801	0.807	0.806
10	25	15:85	0.803	0.808	0.808
11	25	05:95	1.005	0.805	0.805
12	25	0:100	1.006	0.805	0.805

Table 4.30: Adulterate meter evaluation result using Diesel: Alcohol system.

S/N	Temp °C	Diesel/Alcohol Proportion% (v/v)	Modelled Specific Gravity.	Adulterate meter reading	Actual specific gravity
1	25	100:0	0.803	0.801	0.801
2	25	95:05	0.805	0.807	0.807
3	24	85:15	0.811	0.805	0.806
4	25	75:25	0.803	0.807	0.808
5	25	65:35	0.807	0.805	0.808
6	25	55:45	0.809	0.802	0.805
7	23	45:55	0.806	0.805	0.808
8	24	35:65	0.803	0.806	0.808
9	25	25:75	0.801	0.807	0.808
10	25	15:85	0.803	0.808	0.809
11	25	05:95	1.005	0.808	0.807
12	25	0:100	1.006	0.804	0.804

Table 4.31: Adulterate meter evaluation result using Kerosene: Alcohol system.

S/N	Temp °C	Kerosene/Alcohol Proportion% (v/v)	Modelled Specific Gravity.	Adulterate meter reading.	Actual specific gravity.
1	25	100:0	0.830	0.801	0.804
2	25	95:05	0.805	0.807	0.807
3	24	85:15	0.811	0.805	0.805
4	23	75:25	0.803	0.807	0.806
5	23	65:35	0.807	0.805	0.806
6	23	55:45	0.809	0.802	0.805
7	23	45:55	0.806	0.805	0.808
8	24	35: 65	0.803	0.806	0.808
9	24	25:75	0.801	0.807	0.808
10	25	15:85	0.803	0.808	0.809
11	25	05:95	1.005	0.805	0.805
12	25	0:100	1.006	0.805	0.805

4.7 Fuel Contaminated with Heavy Oil (Used Lubricant).

Table 4.32: Adulterate meter evaluation result using Petrol: Heavy oil system.

S/N	Temp °C	Petrol/Heavyoil Proportion% (v/v)	Modelled Specific Gravity	Adulterate meter reading	Actual specific gravity
1	25	100:0	0.830	0.801	0.803
2	25	95:05	0.975	0.808	0.808
3	24	85:15	0.981	0.809	0.807
4	23	75:25	1.989	0.810	0.820
5	23	65:35	1.997	0.845	0.840
6	23	55:45	1.999	0.842	0.841
7	23	45:55	1.995	0.875	0.869
8	24	35:65	1.006	0.896	0.895
9	24	25:75	1.003	0.947	0.945
10	25	15:85	1.001	0.958	0.958
11	25	05:95	0.975	0.950	0.940
12	25	0:100	0.965	0.961	0.965

Table 4.33: Adulterate meter evaluation result using Diesel: Heavy oil system.

S/N	Temp °C	Diesel/Heavy oil Proportion% (v/v)	Modelled Specific Gravity.	Adulterate meter reading	Actual specific gravity
1	25	100:0	0.830	0.800	0.804
2	25	95:05	0.975	0.808	0.804
3	24	85:15	0.981	0.809	0.808
4	23	75:25	0.989	0.810	0.809
5	23	65:35	0.997	0.845	0.845
6	23	55:45	0.999	0.842	0.841
7	23	45:55	0.995	0.875	0.876
8	24	35:65	0.996	0.896	0.897
9	24	25:75	0.993	0.947	0.950
10	25	15:85	0.991	0.958	0.960
11	25	05:95	0.975	0.950	0.960
12	25	0:100	0.965	0.961	0.959

Table 4.34: Adulterate meter evaluation result using Kerosene: Heavy oil mixed system.

S/N	Temp °C	Kerosene/Heavy oil Proportion% (v/v)	Modelled Specific Gravity.	Adulterate meter reading	Actual specific gravity.
1	25	100:0	0.830	0.801	0.803
2	25	95:05	0.975	0.808	0.805
3	24	85:15	0.981	0.809	0.808
4	23	75:25	1.989	0.810	0.813
5	23	65:35	1.997	0.845	0.840
6	23	55:45	1.999	0.842	0.841
7	23	45:55	1.995	0.875	0.873
8	24	35: 65	1.006	0.896	0.894
9	24	25:75	1.003	0.947	0.950
10	25	15:85	1.001	0.958	0.959
11	25	05:95	0.975	0.950	0.950
12	25	0:100	0.965	0.961	0.965

4.8 Adulterate Meter Testing Result with Fuel Contaminated with Solid Particulate

Presented petroleum products (Petrol, Diesel and kerosene) fuel is fairly clean when it leaves the refinery, but becomes contaminated each time it is transferred or stored, the fuel sample with constant volume were prepared with a known quantity of dust as an adulterant. It was observed that the petroleum sample becomes more viscous with increasing in time and quantity of sand.

Table 4.35 – 4.43 show the result of the developed adulterate meter when tested, on adulterated fuel samples of solid contaminant (Sand, ash dust and wood ash). Adulterated fuel samples were prepared with a known volume of Fuel sample (60ml) while varying the known quantity of solid contaminate (Sand, ash dust and wood ash) at ambient Temperature. The table presented the result of the developed mathematical model in Equation 3.5 (Olotu, *et al* 2018) with the volume replaced with mass, which detected adulteration in real-time of 2-4 % by Mass of Contaminants. Meanwhile as presented by Fadairo et al, 2020, who developed a filter/litmus paper for adulteration detector, however, his work did not detect adulteration in real time and the effects of solid particulate contaminant was not captured. It was also proposed by Olanisebe et al, 2013 that the use of water cut meter especially when fuel is adulterated with water in a reservoir is vital, likewise, the effects of solid particulate contaminant was not captured. The lines obtained show that the specific gravity of the sample increases with increase in temperature which is an abnormality. These results explained the general effect of the temperature on specific gravity of adulterated hydrocarbon sample. The new adulterate meter readings and the actual readings majorly, has no significant difference as well. This design also compensate for temperature variation.

It can also be stated that the Solid contaminant had little or no significant effect on fuel adulteration, especially sand dust, saw dust and ash. The results of Kerosene, Petrol, Naphtha, Diesel adulterated with Solid contaminant shows no effect even up to about 80% level of contamination, it was also noticed that they were very well within the regulatory specifications of fuel even within about 80% level of contamination. It's also emerges out broadly from the outcomes of this study that monitoring adulteration of Petrol, kerosene

and Diesel fuel with solid contaminant especially of fine particulate matter is of no significant impact.

UNIVERSITY OF IBADAN LIBRARY

Table 4.35: Adulterate meter evaluation result with Petrol Contaminated with Sand dust.

S/N	Temp °C	Petrol (ml)	Sample	Sand dust Particle(g)	Modelled Specific Gravity.	Adulterate meter readings	Experimental specific gravity
1	27	60		0	0.890	0.890	0.895
2	25	60		2	0.909	1.260	1.259
3	26	60		4	0.929	1.580	1.557
4	27	60		6	0.947	1.560	1.585
5	26	60		8	0.969	1.760	1.780
6	27	60		10	0.989	1.920	1.980

Table 4.36: Adulterate meter evaluation result with Diesel Contaminated with Sand dust.

S/N	Temp °C	Diesel Sample (l)	Sand dust Particle(g)	Modelled Gravity.	SpecificAdulterate meter reading	Experimental specific gravity
1	27	60	0	0.877	0.890	0.881
2	27	60	2	0.895	1.060	1.051
3	26	60	4	0.989	1.098	1.081
4	27	60	6	0.998	1.076	1.075
5	26	60	8	0.984	1.142	1.119
6	27	60	10	0.897	1.011	1.011

Table 4.37: Adulterate meter evaluation result with kerosene Contaminated with Sand dust.

S/N	Temp °C	Kerosene Sample (l)	Sand dust Particle(g)	Modelled Specific Gravity	Adulterate meter reading	Experimental specific gravity
1	27	60	0	0.887	0.890	0.882
2	27	60	2	1.890	1.880	1.880
3	26	60	4	1.897	1.980	1.980
4	27	60	6	1.980	1.980	1.980
5	26	60	8	1.887	1.781	1.782
6	27	60	10	1.787	1.961	1.961

4.9 Adulterate Meter Testing Result with Fuel Contaminated with Saw Dust particulate

Table 4.38: Adulterate meter evaluation result with Petrol Contaminated with saw dust.

S/N	Temp °C	Petrol Sample (ml)	Saw dust Particle(g)	Modelled Specific Gravity.	Adulterate meter reading	Experimental specific gravity
1	27	60	0	0.899	0.880	0.887
2	25	60	2	0.889	0.885	0.886
3	26	60	4	0.989	0.887	0.887
4	27	60	6	0.998	0.887	0.888
5	26	60	8	1.009	0.885	0.887
6	27	60	10	1.021	0.890	0.893

Table 4.39: Adulterate meter evaluation result with Diesel Contaminated with saw dust.

S/N	Temp °C	Diesel Sample (l)	Saw dust Particle(kg)	Modelled Specific Gravity	Adulterate meter reading g/cm³	Experimental specific gravity
1	27	60	0	0.887	0.882	0.883
2	27	60	2	0.883	0.882	0.883
3	26	60	4	0.885	0.883	0.884
4	27	60	6	0.889	0.884	0.885
5	26	60	8	0.998	0.886	0.886
6	27	60	10	0.999	0.886	0.887

Table 4.40: Adulterate meter evaluation result with kerosene Contaminated with saw dust

S/N	Temp °C	Kerosene Sample (l)	Saw dust Particle(kg)	Modelled Specific Gravity/cm ³ .	Adulterate- meter reading	Experimental specific gravity
1	27	60	0	0.860	0.880	0.883
2	27	60	2	0.870	0.880	0.881
3	26	60	4	0.880	0.880	0.881
4	27	60	6	0.890	0.980	0.980
5	26	60	8	0.980	0.981	0.982
6	27	60	10	0.990	0.991	0.992

4.10 Adulterate Meter Testing result with Fuel Contaminated with Ashes Particulate.



Figure 4.1: The designed Adulterate meter

Table 4.41: Shows the Adulterate meter evaluation result with Petrol Contaminated with ash.

S/N	Temp °C	Petrol Sample (ml)	Ash Particle(g)	Modelled Specific Gravity.	Adulterate meter reading.	Experimen tal specific gravity.
1	27	60	0	0.880	0.890	0.890
2	25	60	2	0.890	0.890	0.890
3	26	60	4	0.923	0.900	0.900
4	27	60	6	0.929	0.890	0.890
5	26	60	8	0.932	0.901	0.901
6	27	60	10	0.942	0.911	0.911

Table 4.42: Shows the Adulterate meter evaluation result with Diesel Contaminated with ash.

S/N	Temp °C	Diesel Sample (ml)	Ash Particle(g)	Modelled Specific Gravity	Adulterate meter reading	Experimental specific gravity g/cm ³
1	27	60	0	0.870	0.890	0.887
2	27	60	2	0.880	0.890	0.880
3	26	60	4	0.868	0.898	0.892
4	27	60	6	0.845	0.890	0.885
5	26	60	8	0.883	0.901	0.883
6	27	60	10	0.832	0.911	0.890

Table 4.43: Shows the Adulterate meter evaluation result with kerosene Contaminated with Ash.

S/N	Temp °C	Kerosene Sample (l)	Ash Particle(g)	Modelled Specific Gravity.	Adulterate meter reading.	Experimental specific gravity.
1	27	60	0	0.870	0.890	0.880
2	27	60	2	0.880	0.890	0.898
3	26	60	4	0.898	0.900	0.885
4	27	60	6	0.870	0.890	0.890
5	26	60	8	0.898	0.901	0.898
6	27	60	10	0.991	0.911	0.910

4.11 Adulterate meter Testing Result with Pump Station Fuel.

Petroleum Products (Petrol, Diesel and kerosene) were bought from the pump station at Total Filling station, Eti-osa local government area, and was tested using the Adulterate meter, as reported by Olotu *et al*, (2018). 86% of fuel adulteration experience by respondent were from the Pump station. It is pertinent to carry out a test with the developed Adulterate meter, to ascertain that the device addresses the challenge. Table 4.44 presented the result obtained.

Table 4.44: Shows the Adulterate meter evaluation result with Pump Station (Petrol, Kerosene and Diesel Sample).

S/N	Temp °C	Petrol Sample (l)	Adulterate meter reading	Kerosene Sample (l)	Adulterate meter reading	Diesel Sample (l)	Adulterate meter reading
1	27	20	0.895	20	0.815	20	0.885
2	27	40	0.894	40	0.816	40	0.885
3	26	60	0.893	60	0.815	60	0.885
4	27	80	0.893	80	0.816	80	0.885
5	27	100	0.893	100	0.815	100	0.885

4.12 Comparative Plots of the Experimental Result and adulterate Meter Readings.

Fig 4.2 -4.30 show the behaviour of each sample is therefore affected by the volume of adulterant. Thus, the plots of Specific gravity against the temperature of adulterate meter and the developed mathematical correlation is as shown below. As predicted by Olotu, 2018, the sensitivity of the mathematical model reflects on the adulterate meter readings indicating that adulteration is detected at 20 - 40% concentration by volume of petroleum product contaminant and that the Temperature of the sample increases with increase in specific gravity.

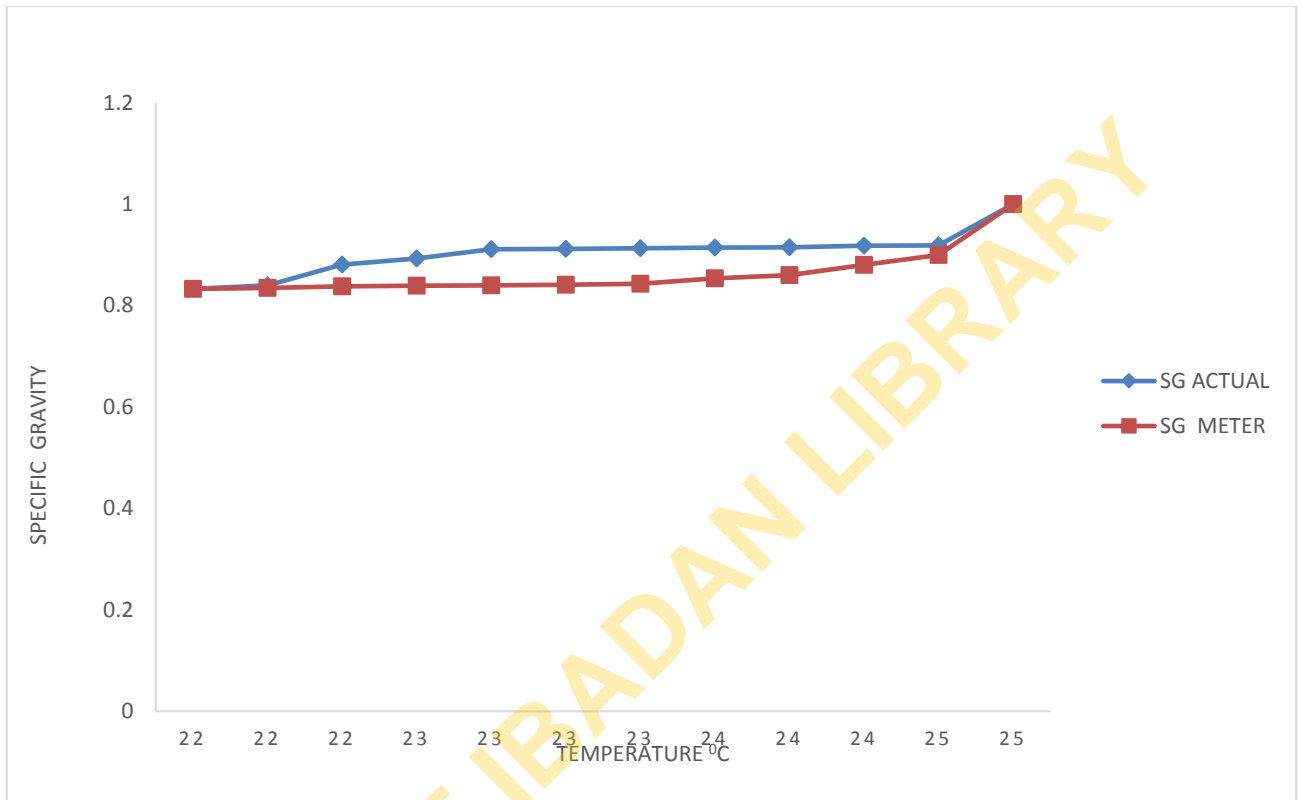

Figure 4.2: Specific Gravity versus Temperature of Petrol/Water mixture

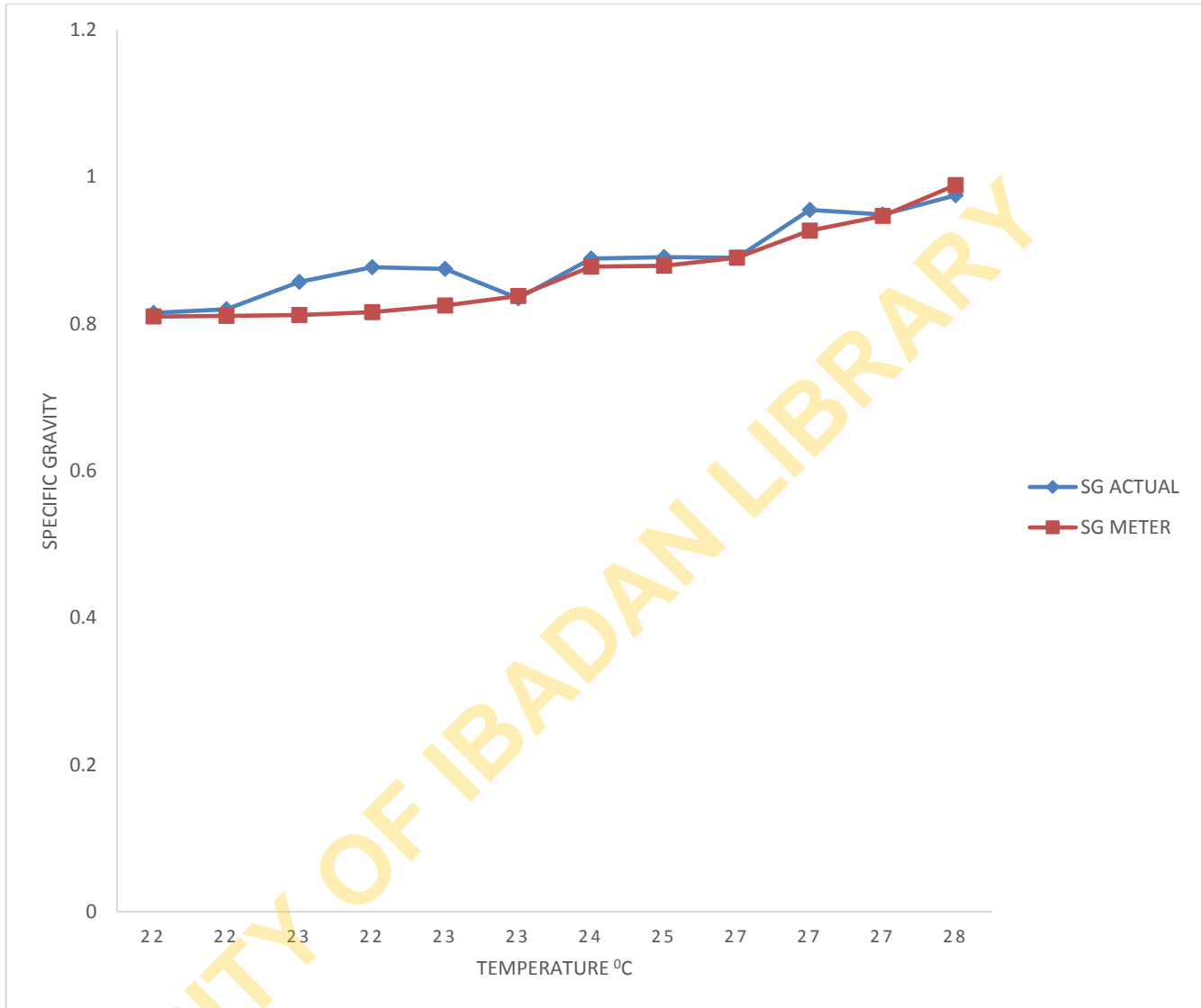

Figure 4.3: Specific Gravity versus Temperature of kerosene/Water Mixture

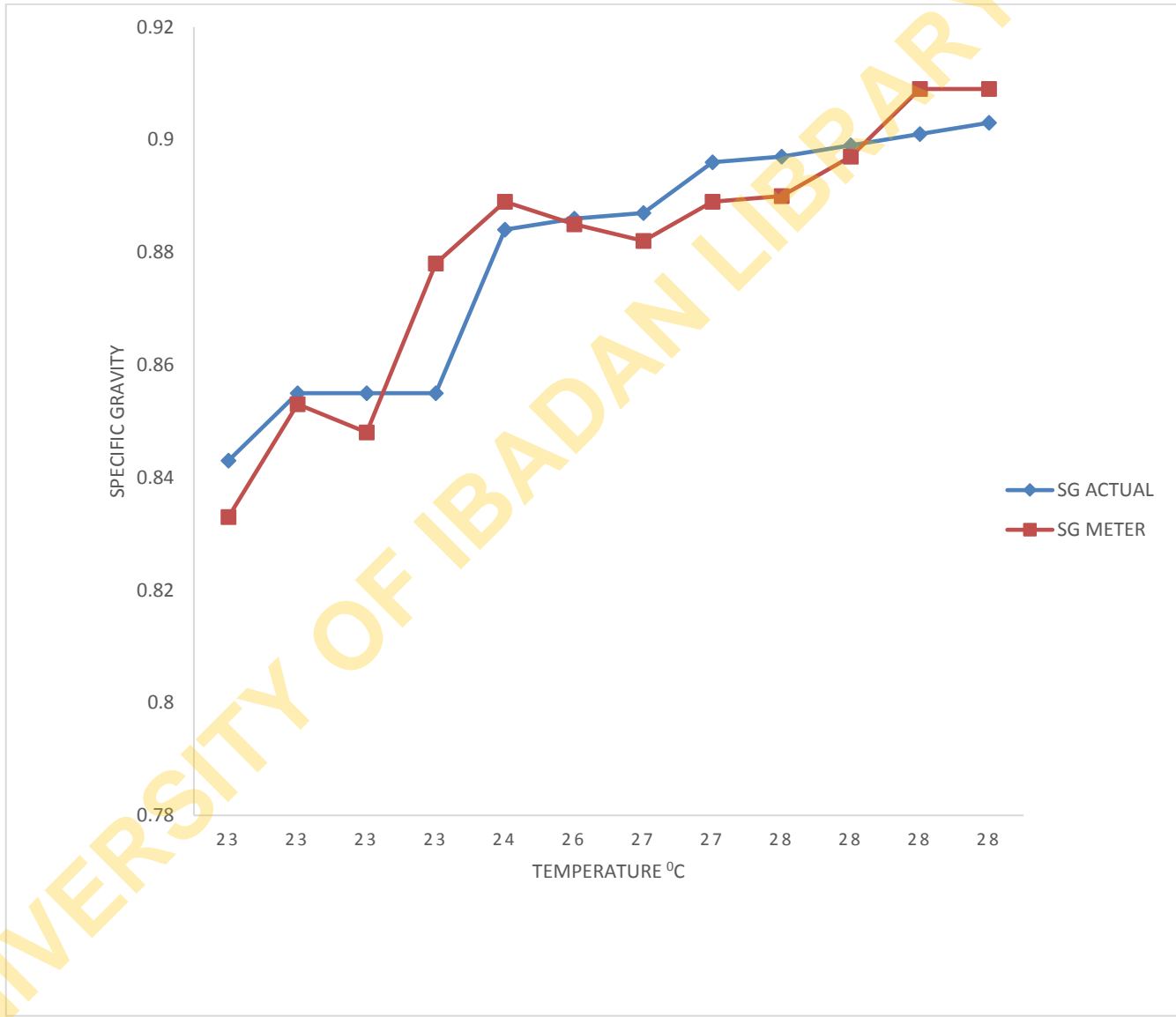

Figure 4.4: Specific Gravity versus Temperature of Diesel/Water mixture.

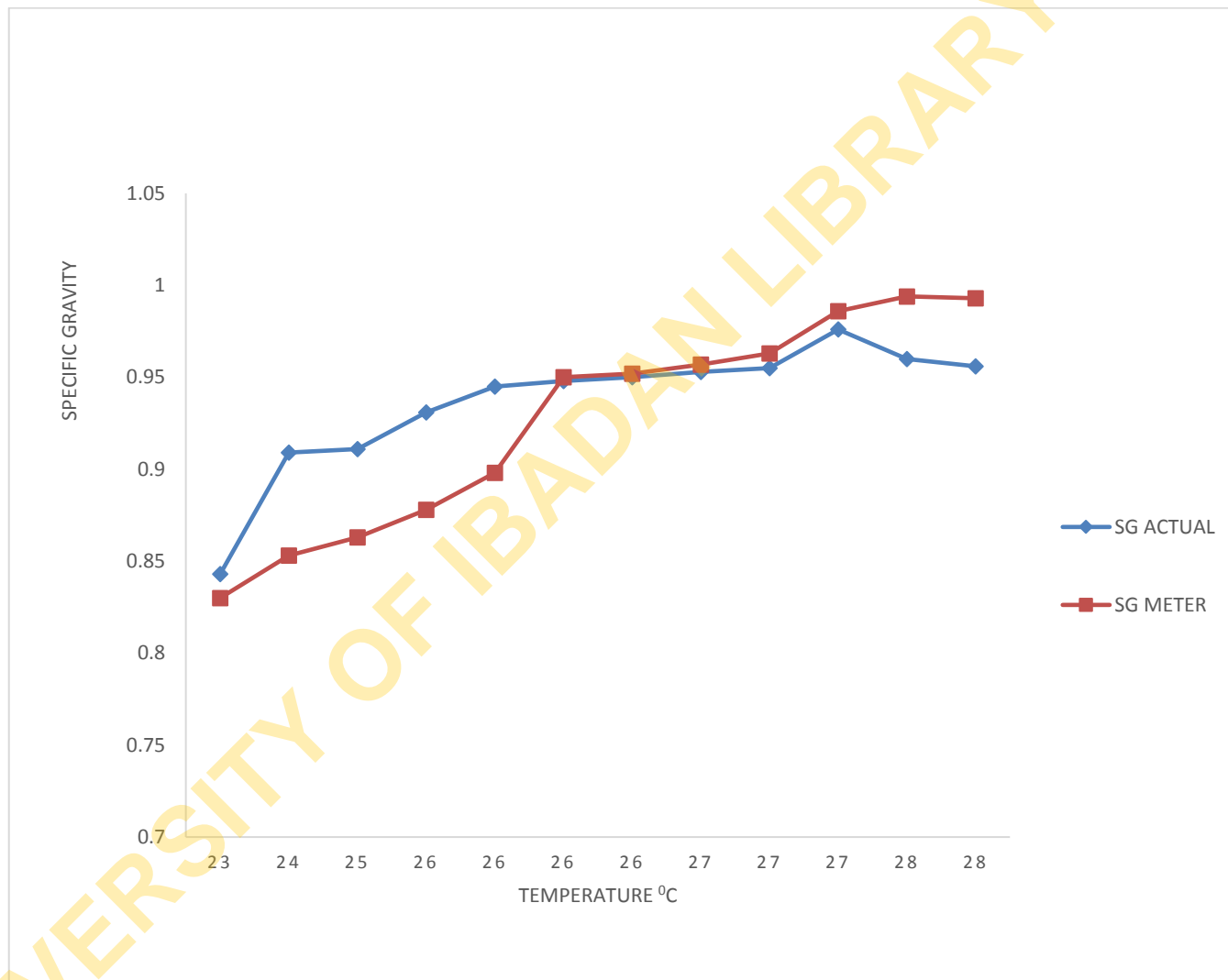

Figure 4.5: Specific Gravity versus Temperature of Diesel/Petrol

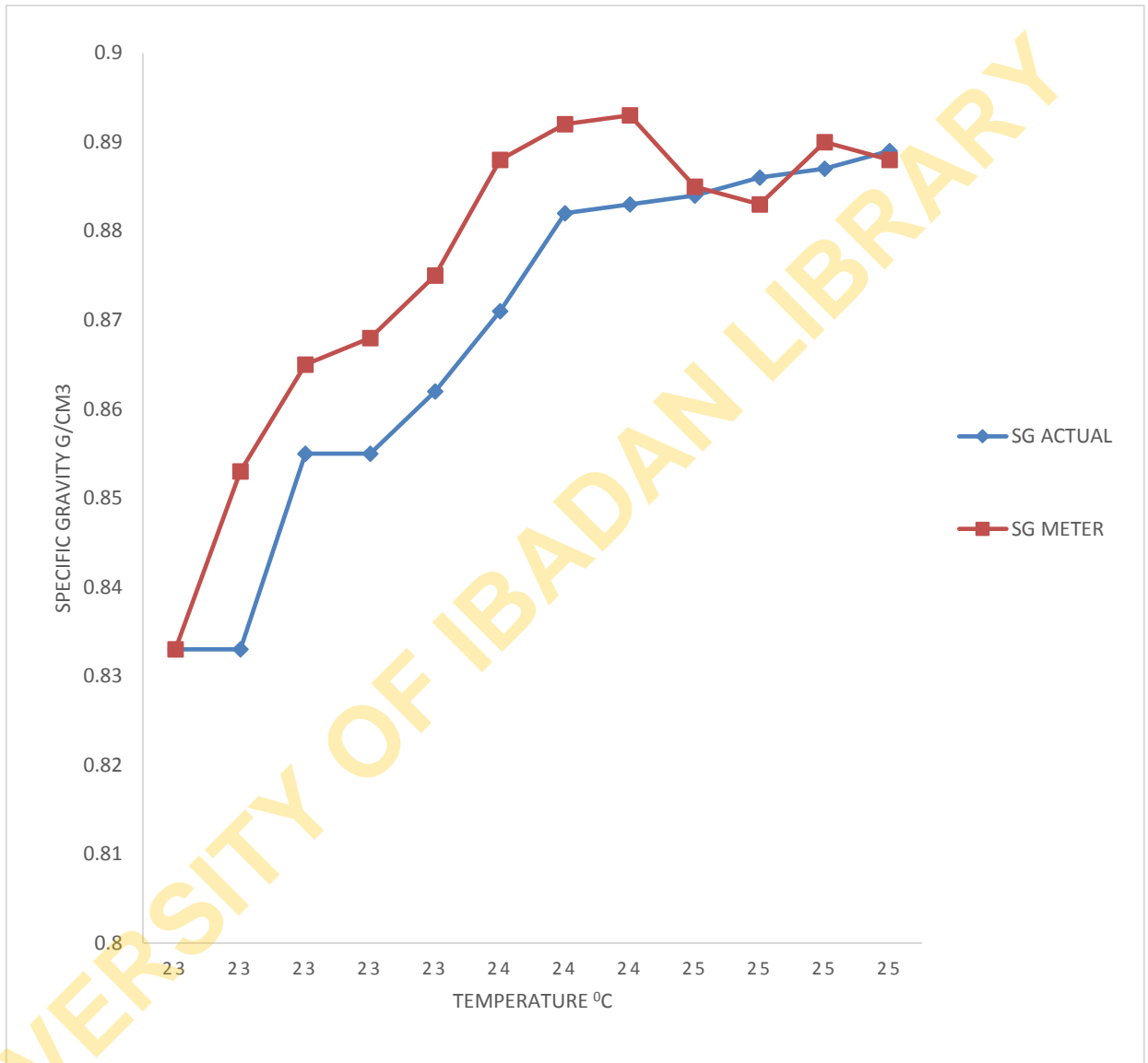

Figure 4.6: Specific Gravity versus Temperature of kerosene/Petrol.

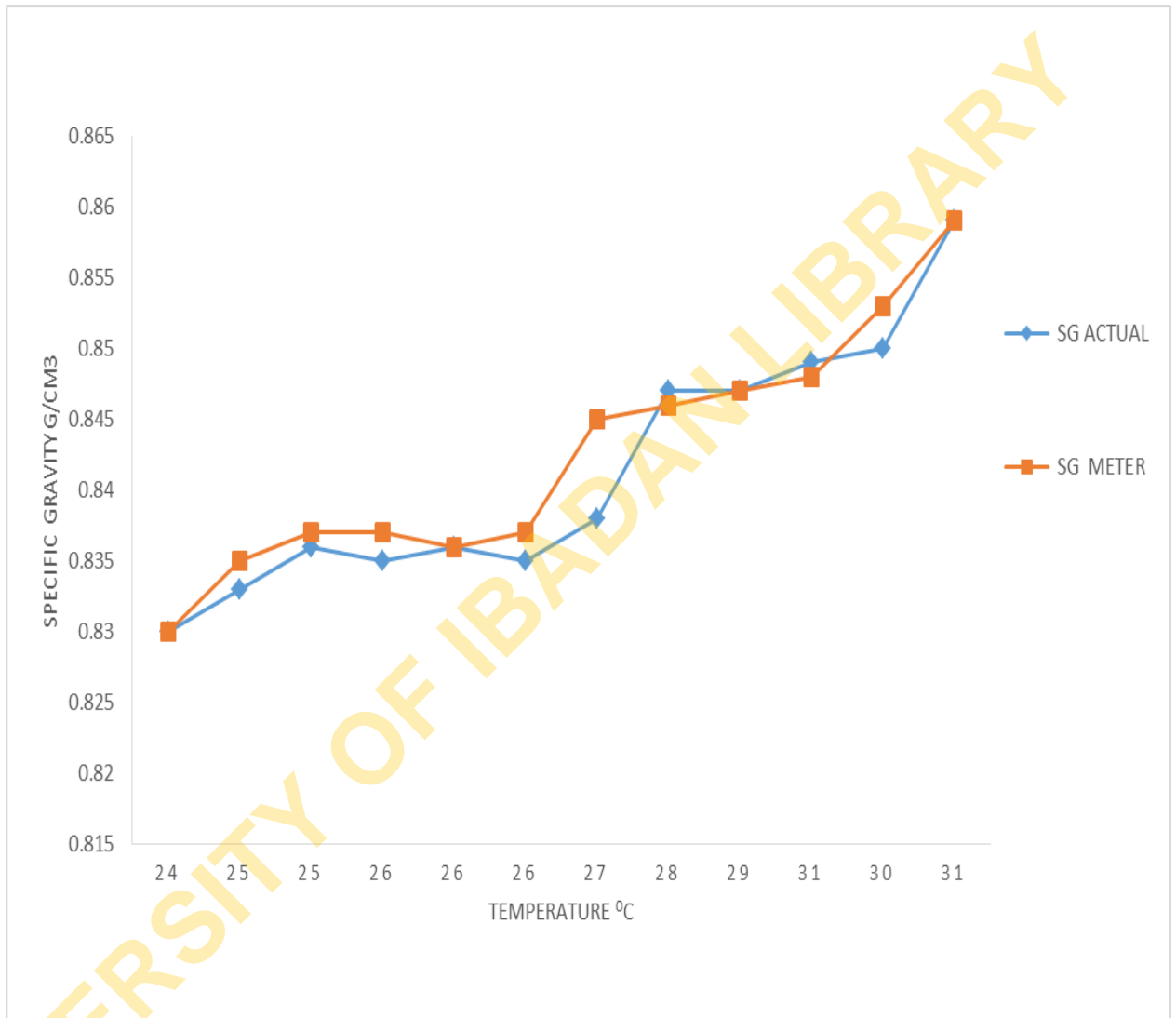

Figure 4.7: Specific Gravity versus Temperature of kerosene/Diesel mixture.

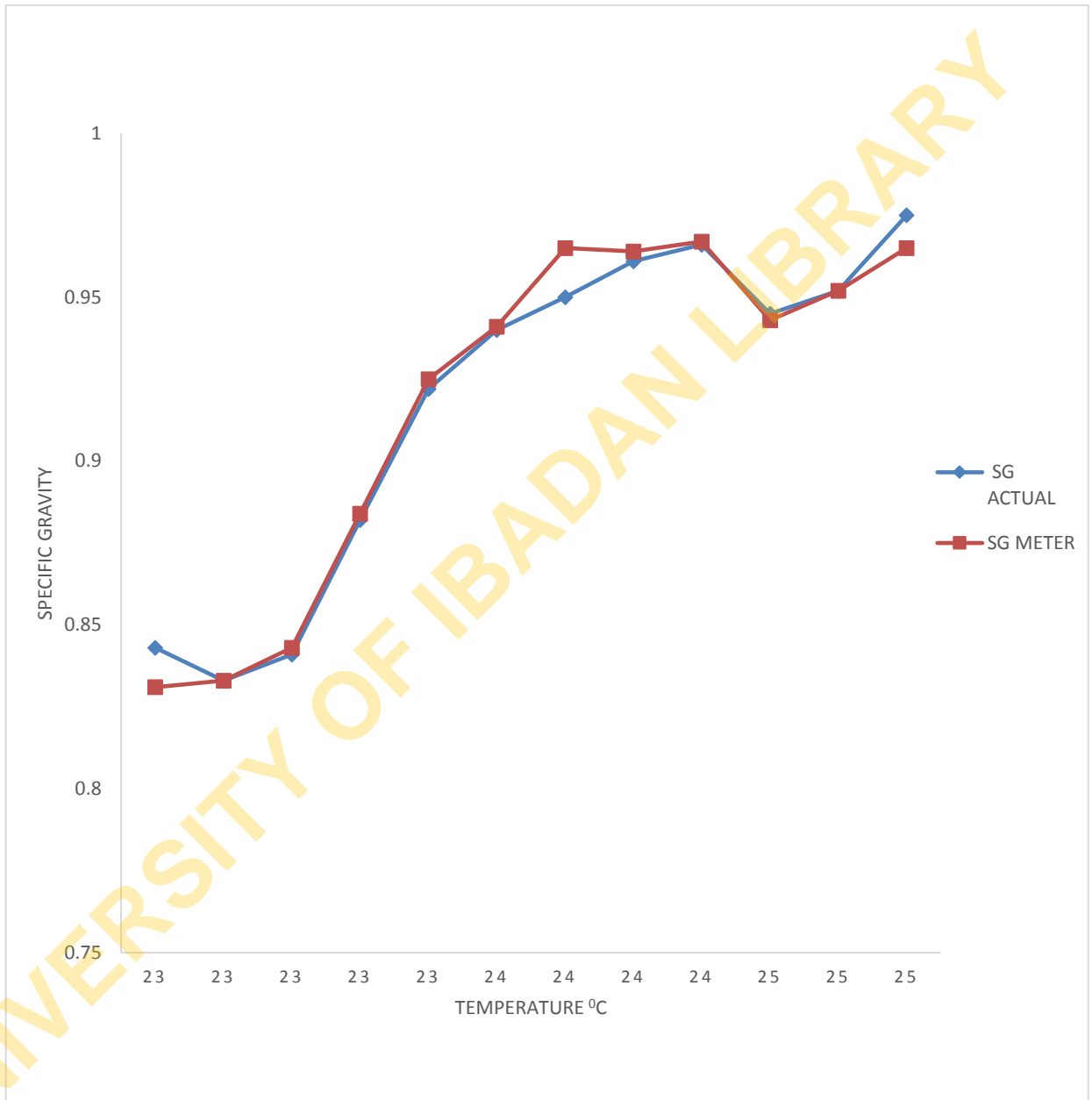

Figure 4.8: Specific Gravity versus Temperature of Petrol/Naphtha mixture

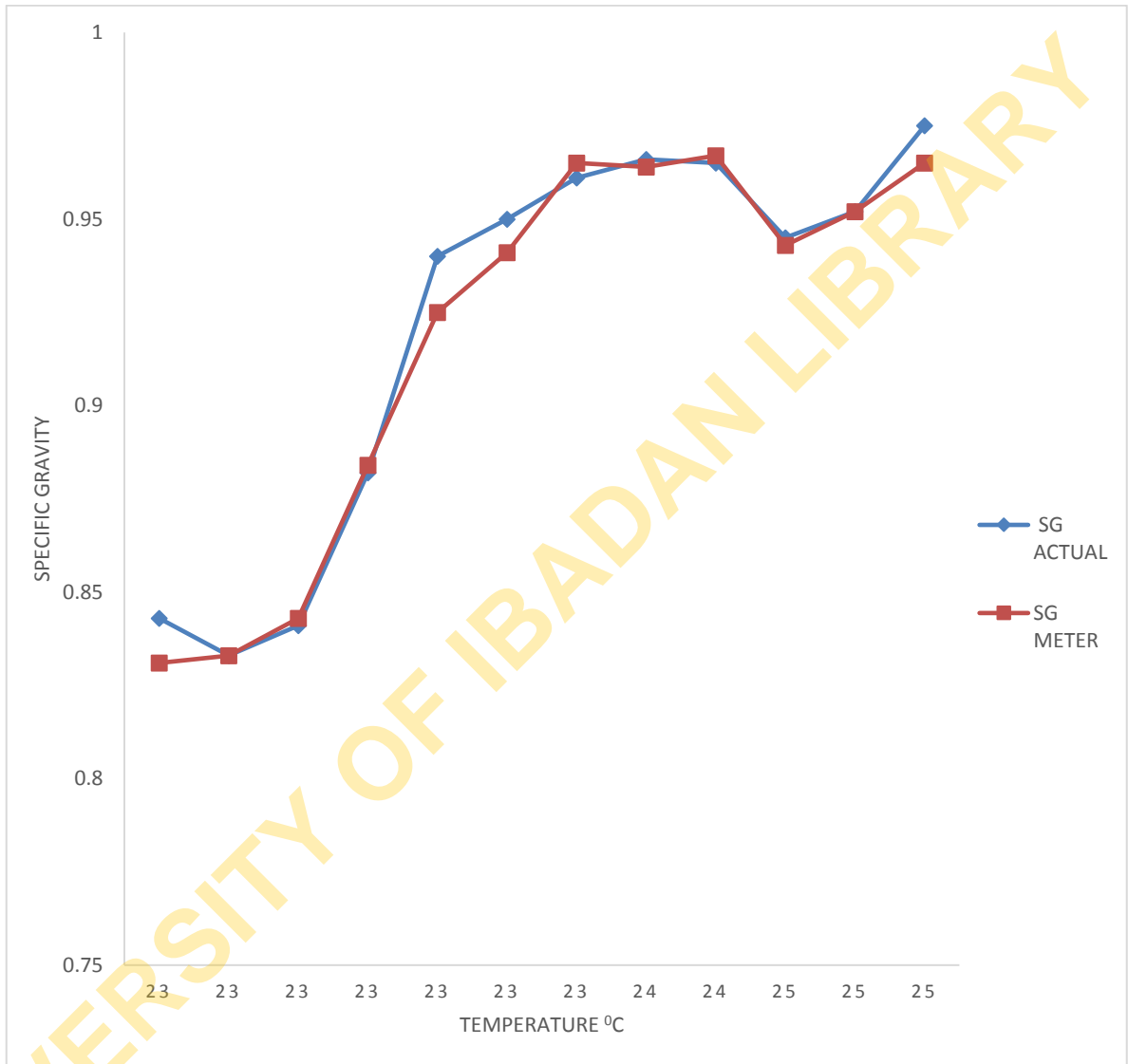

Figure 4.9: Specific Gravity versus Temperature of Diesel/Naphtha mixture.

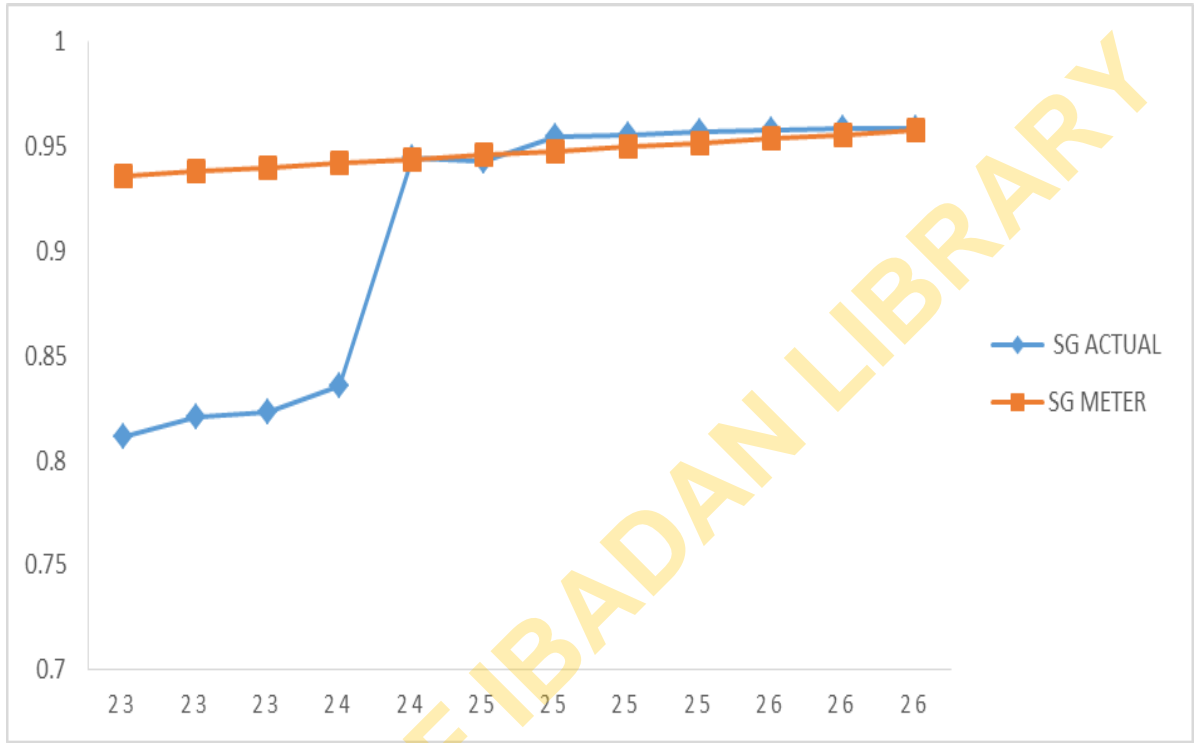

Figure 4.10: Specific Gravity versus Temperature of Petrol/Lubricating oil mixture

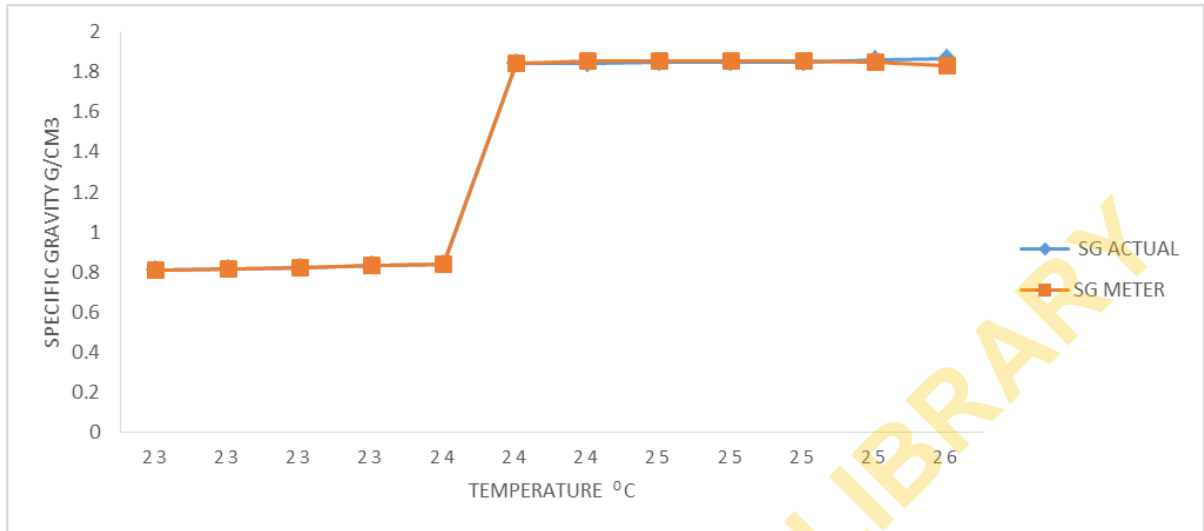

Figure 4.11: Specific Gravity versus Temperature of Diesel/Lubricating oil mixture

UNIVERSITY OF IBADAN LIBRARY

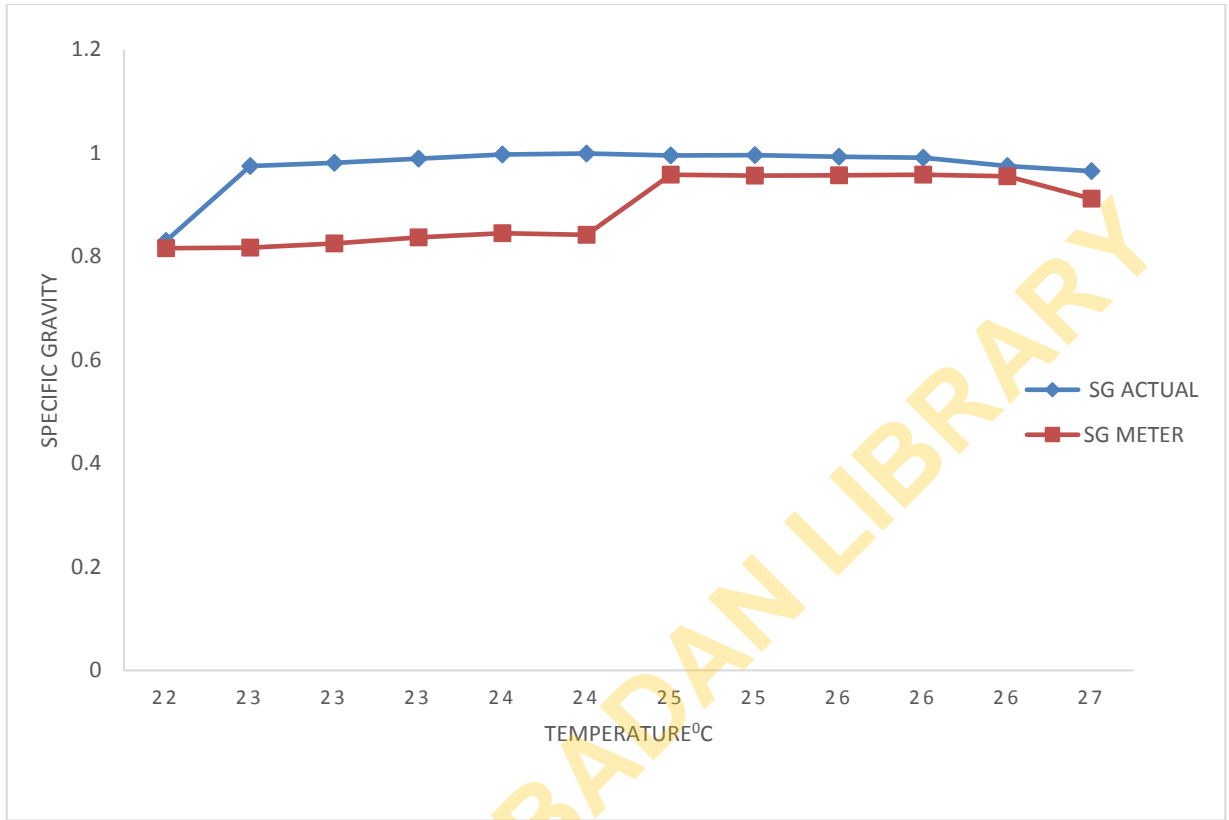

Figure 4.12: Specific Gravity versus Temperature of kerosene/Lubricating oil mixture

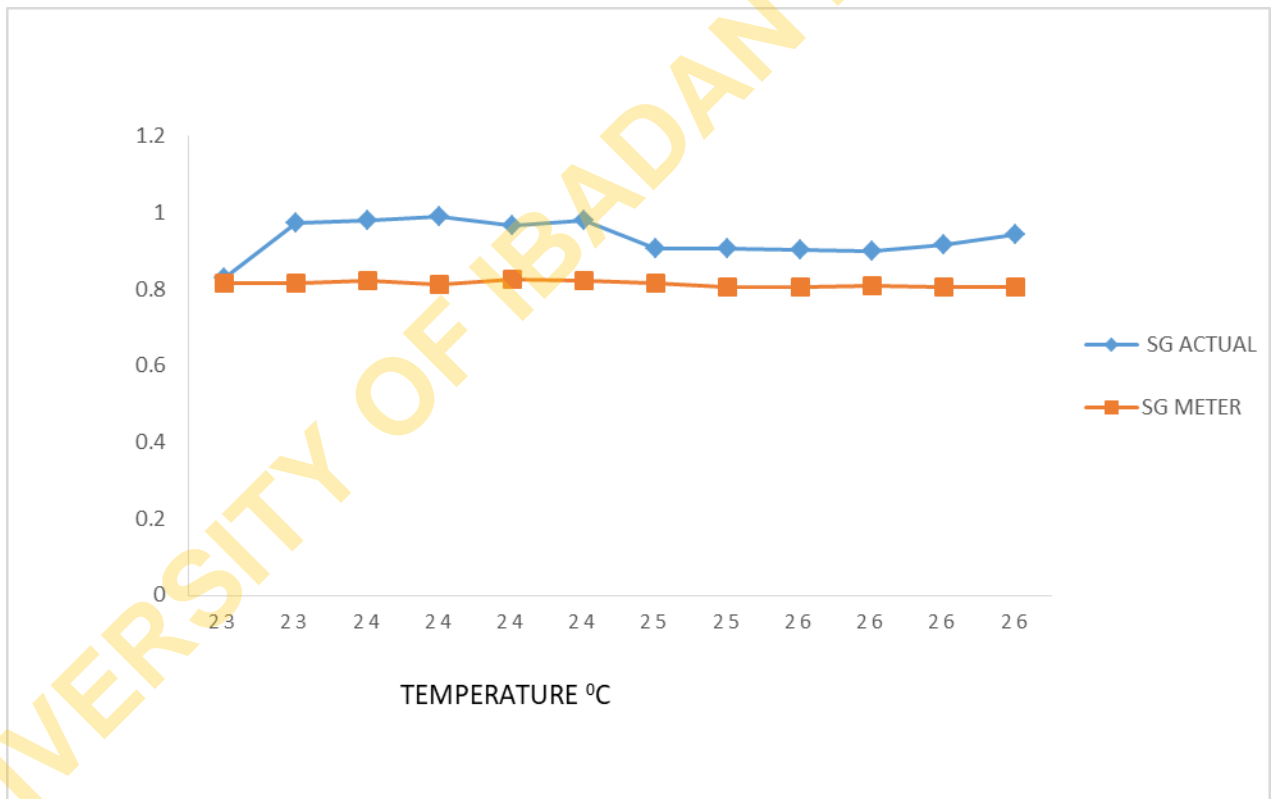

Figure 4.13: Specific Gravity versus Temperature of Petrol/Fuel oil mixture.

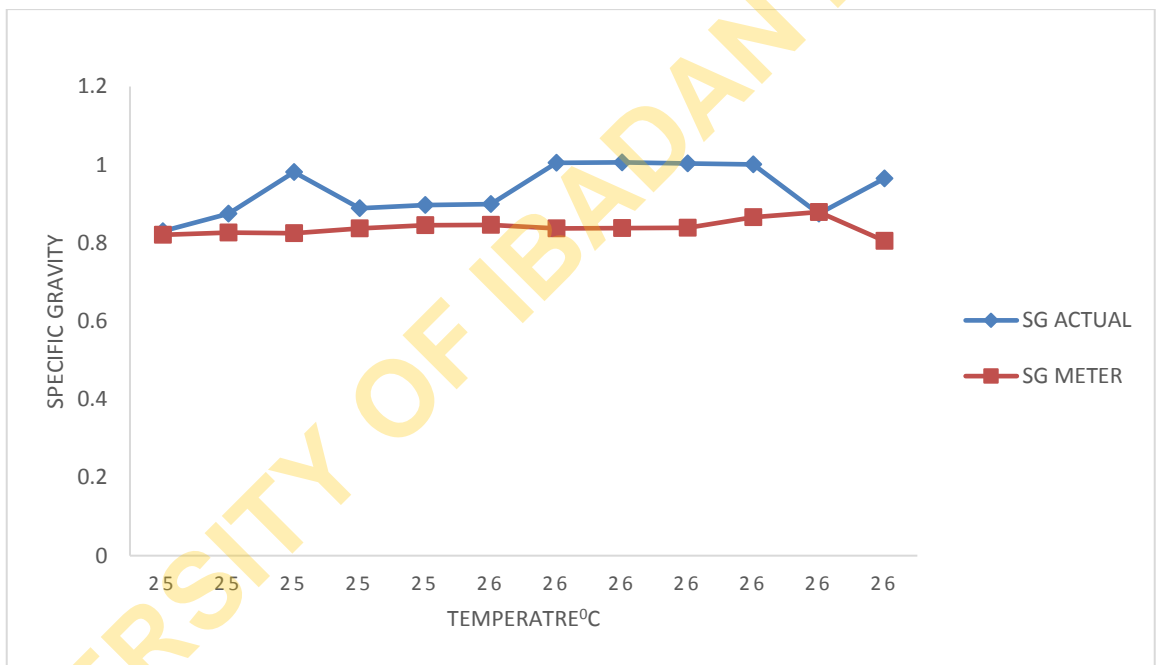

Figure 4.14: Specific Gravity versus Temperature of Diesel/Fuel oil mixture

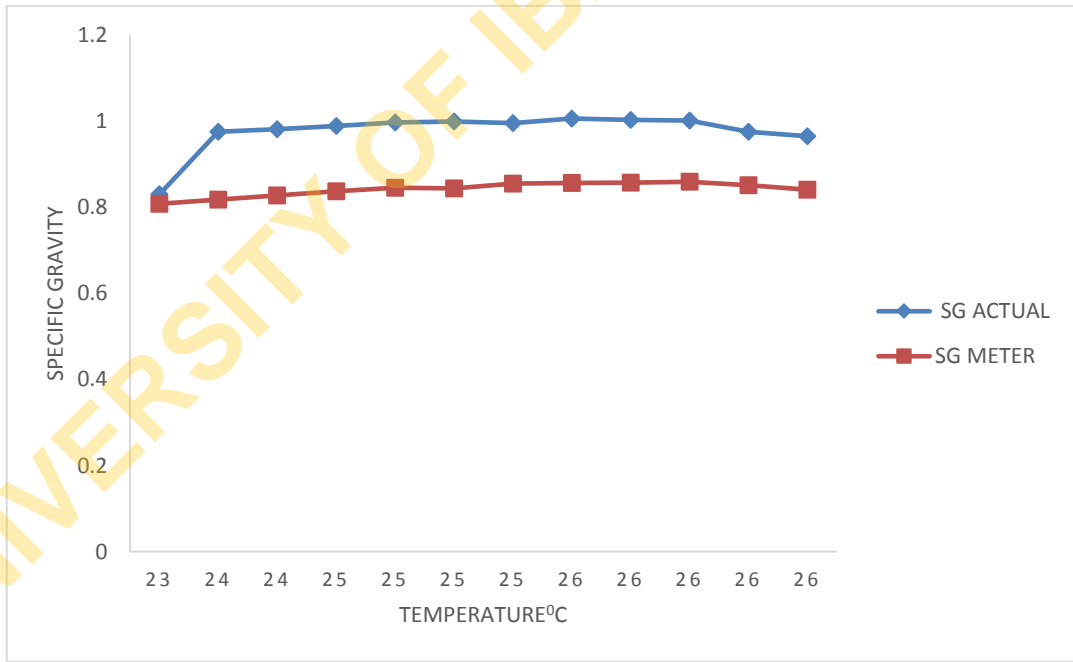

Figure 4.15: Specific Gravity versus Temperature of Kerosene/Fuel oil mixture

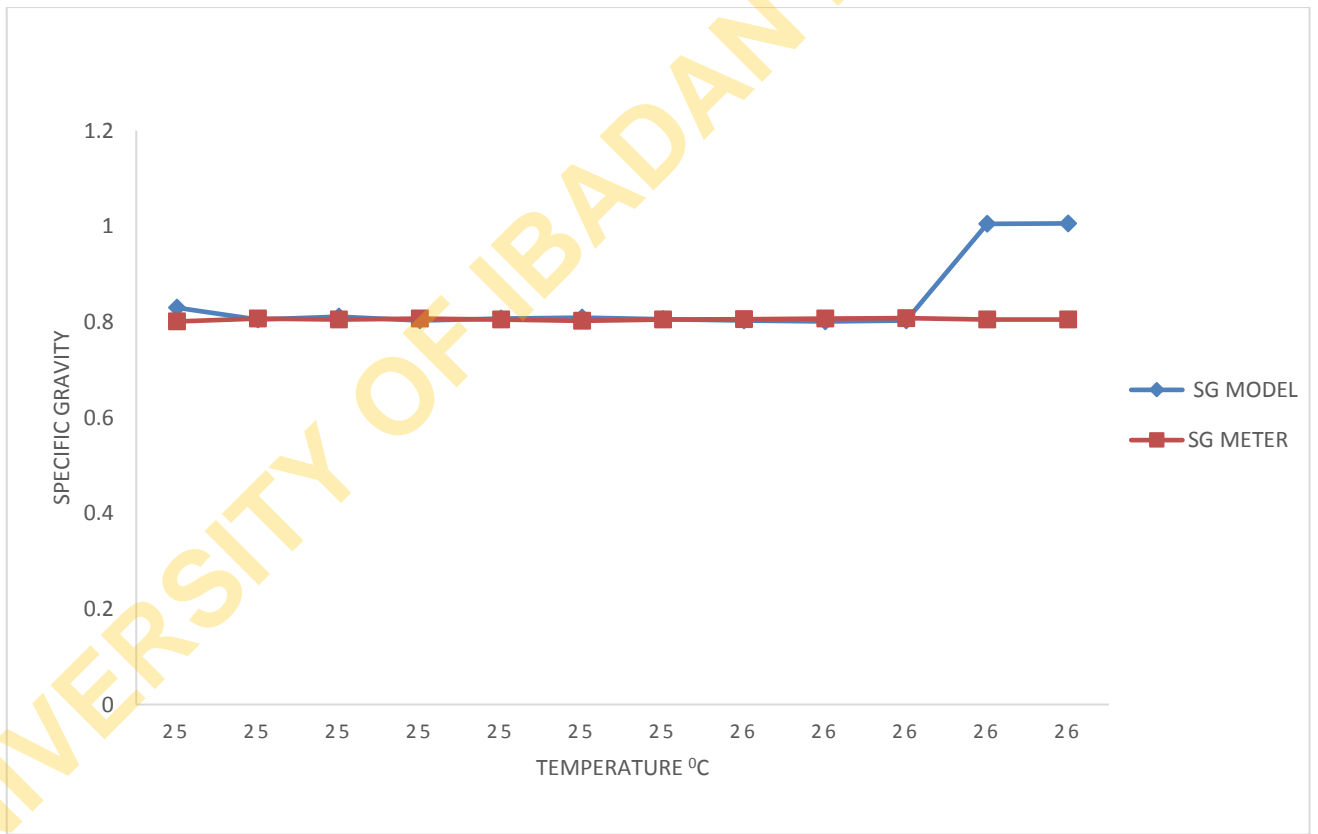

Figure 4.16: Specific Gravity versus Temperature of Petrol/Alcohol mixture

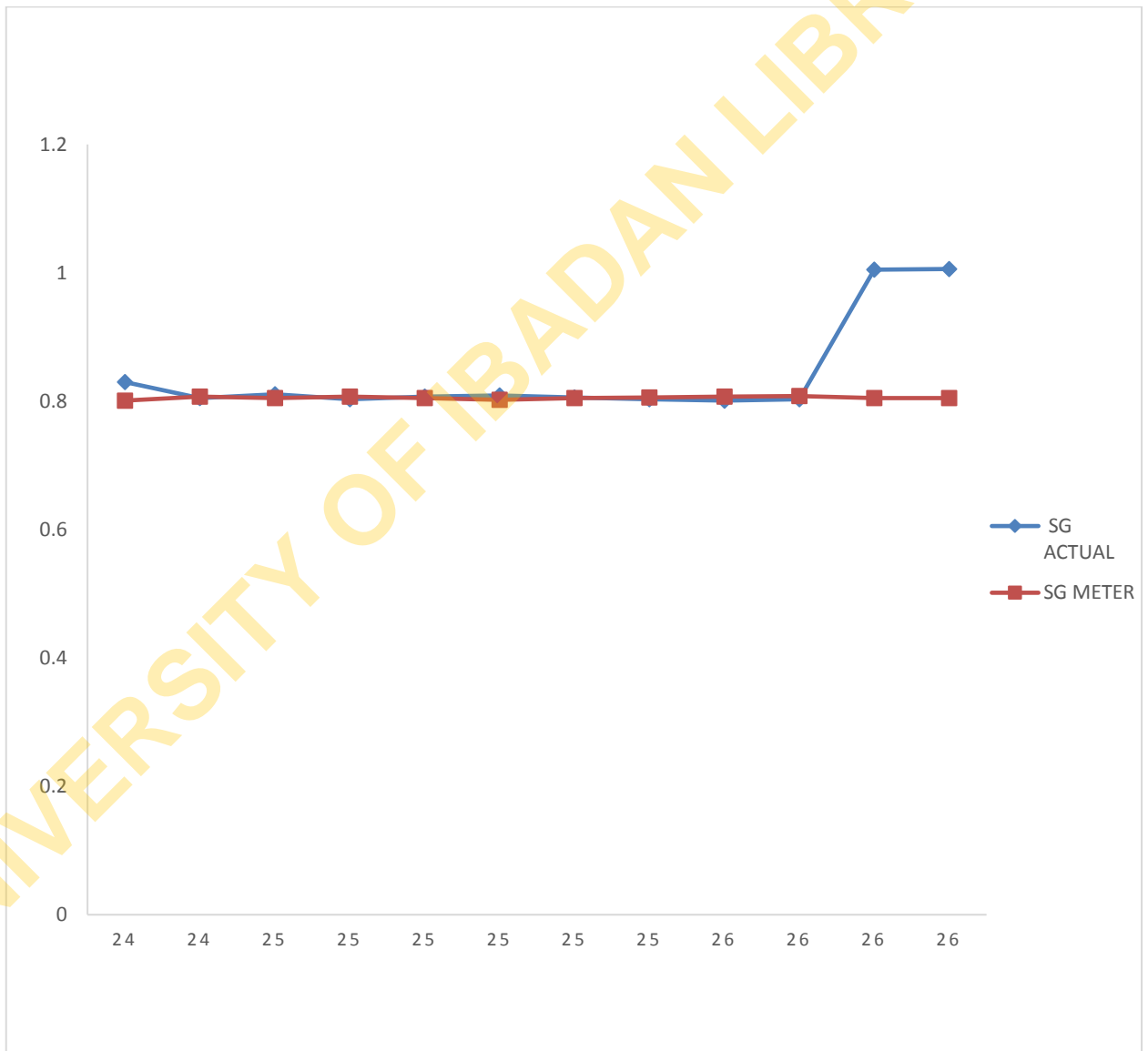

Figure 4.17: Specific Gravity versus Temperature of Diesel/Alcohol mixture

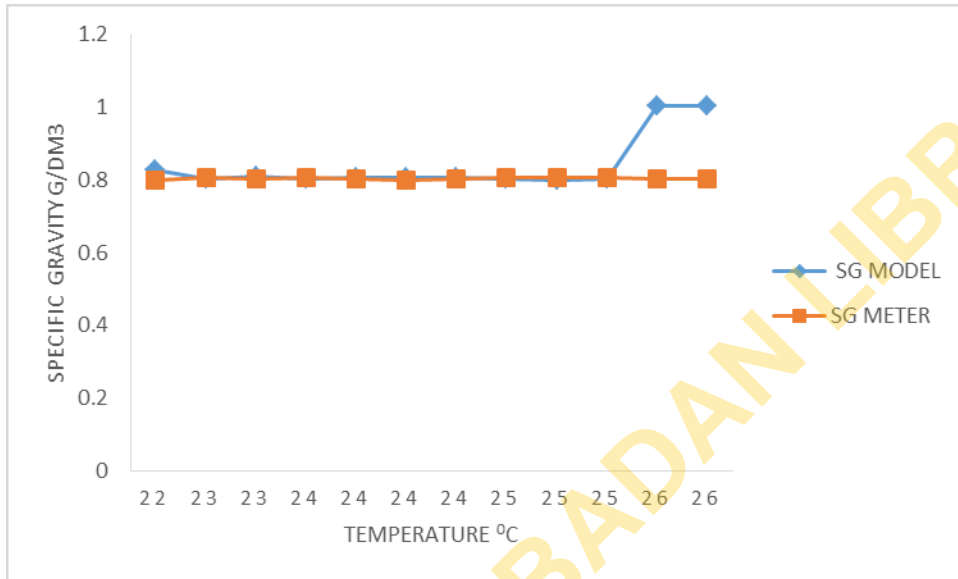

Figure 4.18: Specific Gravity versus Temperature of Kerosene/Alcohol mixture

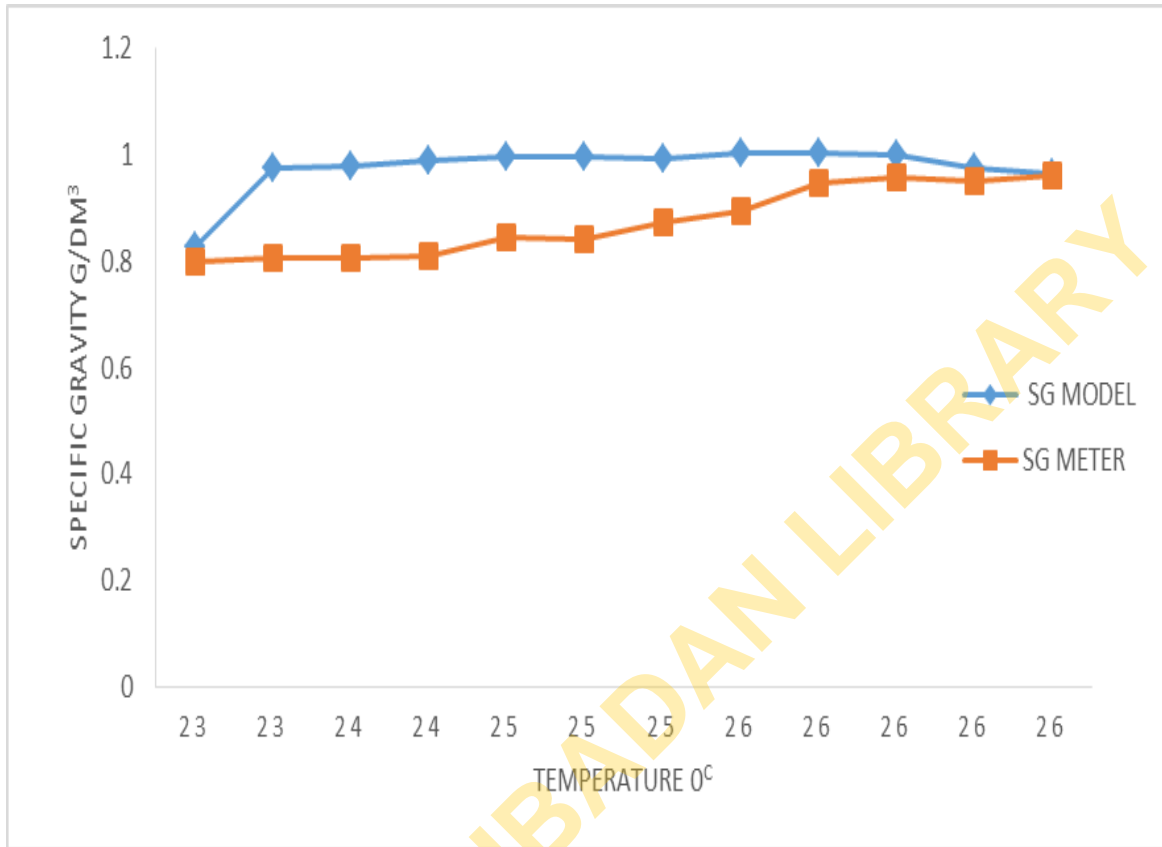

Figure 4.19: Specific Gravity versus Temperature of Petrol/Heavy Oil mixture

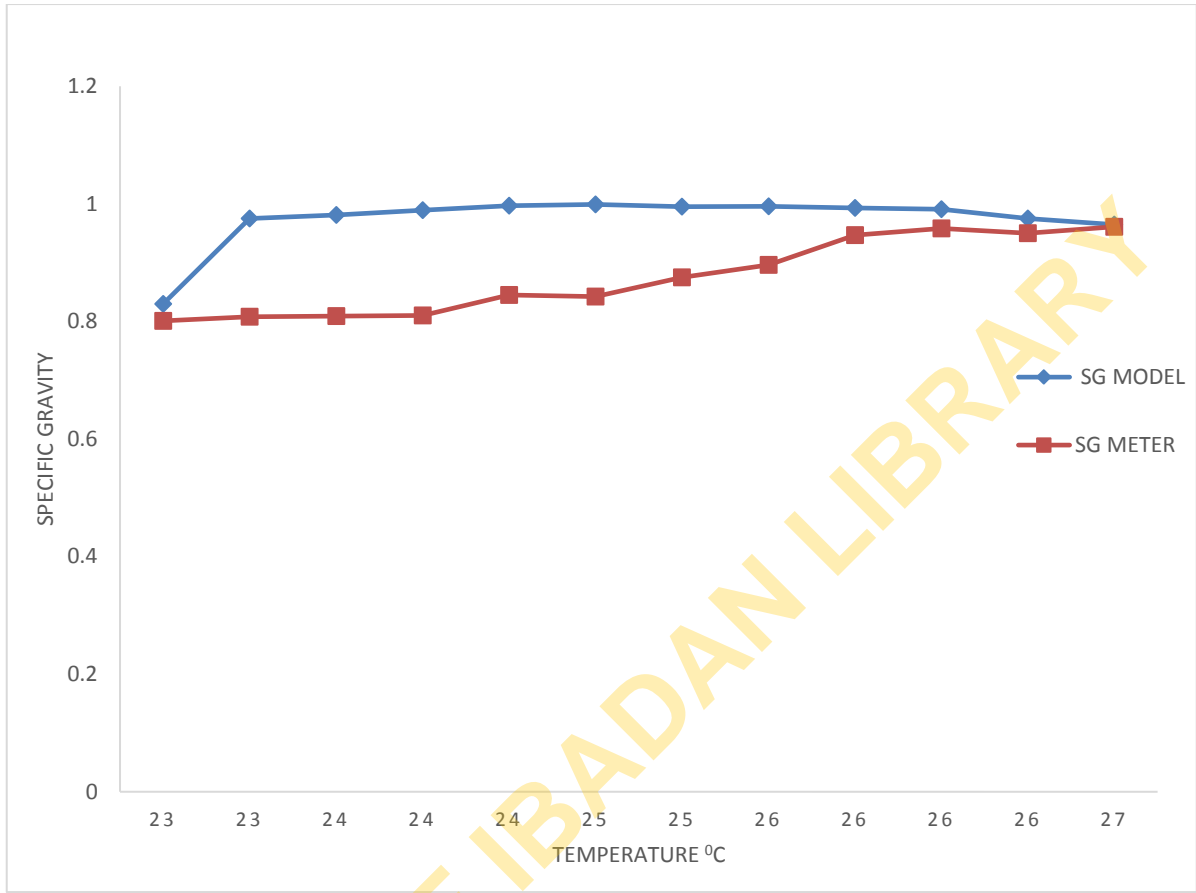

Figure 4.20: Specific Gravity versus Temperature of Diesel/Heavy oil mixture

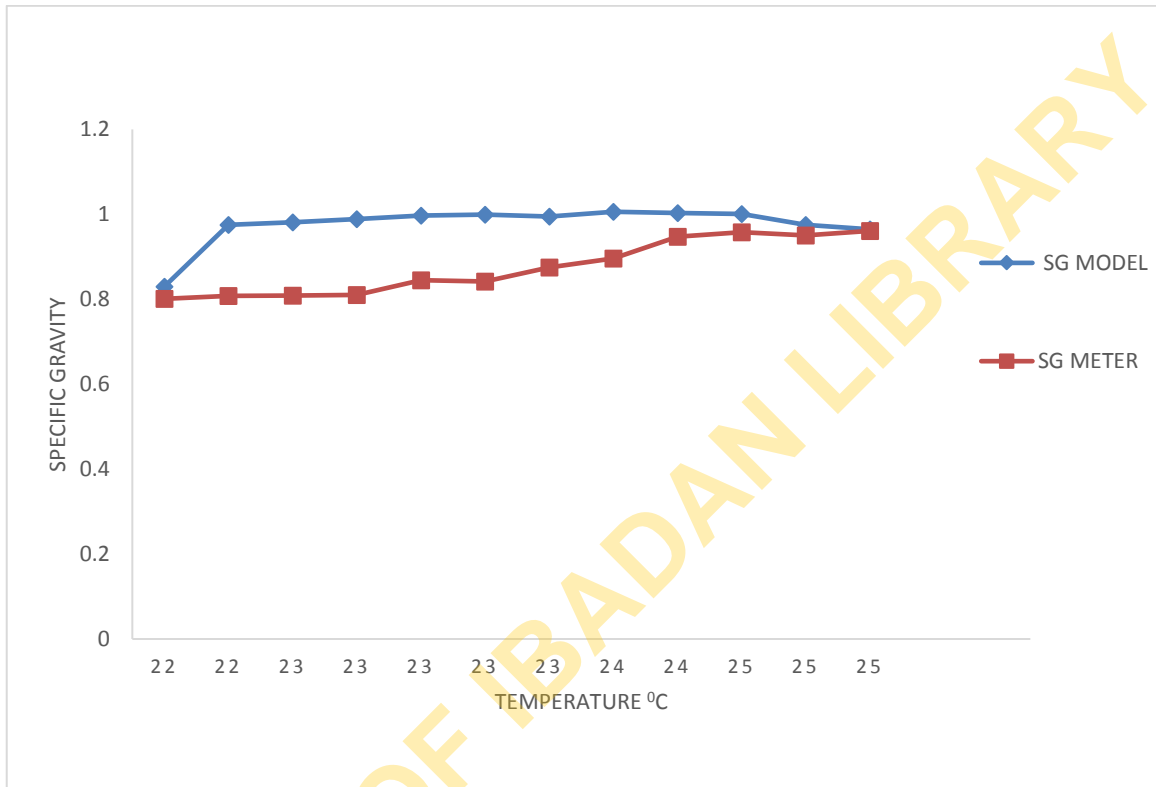

Figure 4.21: Specific Gravity versus Temperature of Kerosene/Heavy oil mixture

4.13 Comparative Plots for the Adulterate Meter and Mathematical Correlation with Solid Particulate as Adulterant.

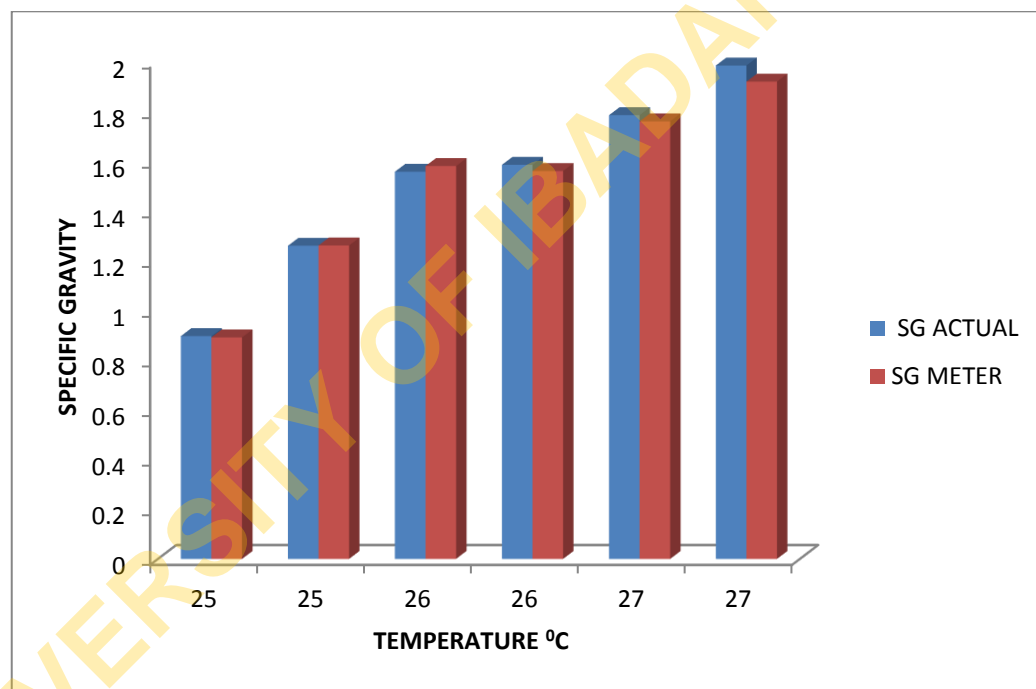

Figure 4.22: Specific Gravity versus Temperature of Petrol /Sand dust mixture

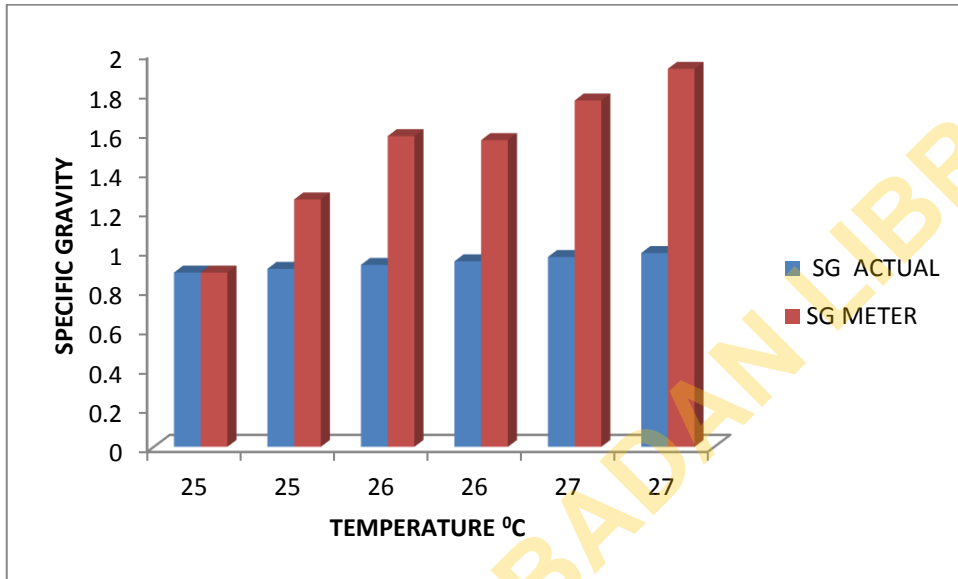

Figure 4.23: Specific Gravity versus Temperature of Diesel /Sand dust mixture

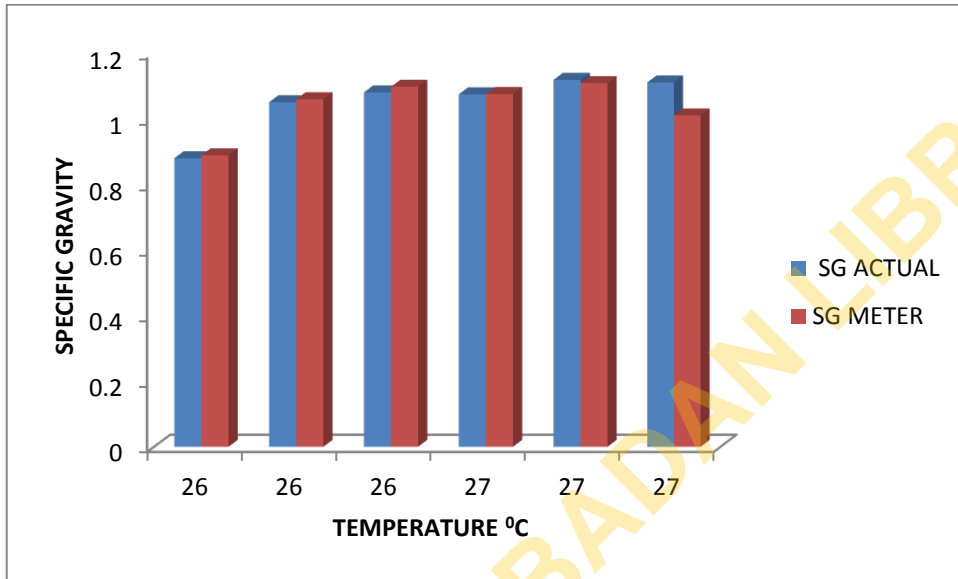

Figure 4.24: Specific Gravity versus Temperature of Kerosene/Sand dust mixture

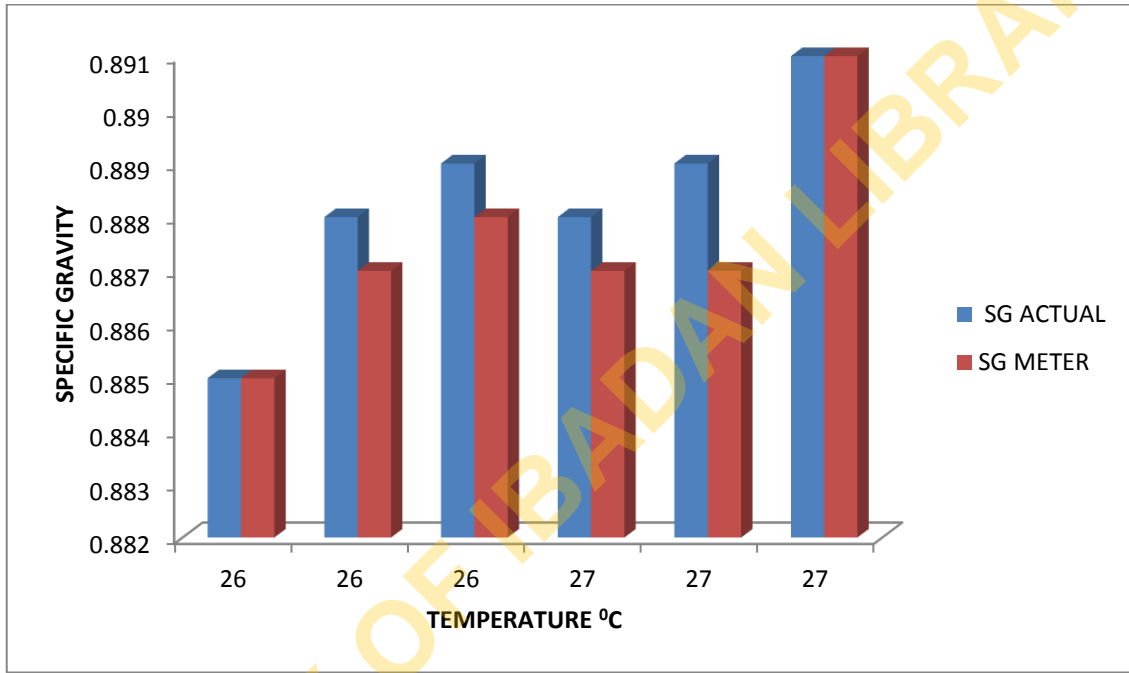

Figure 4.25: Specific Gravity versus Temperature of Petrol/Saw dust mixture

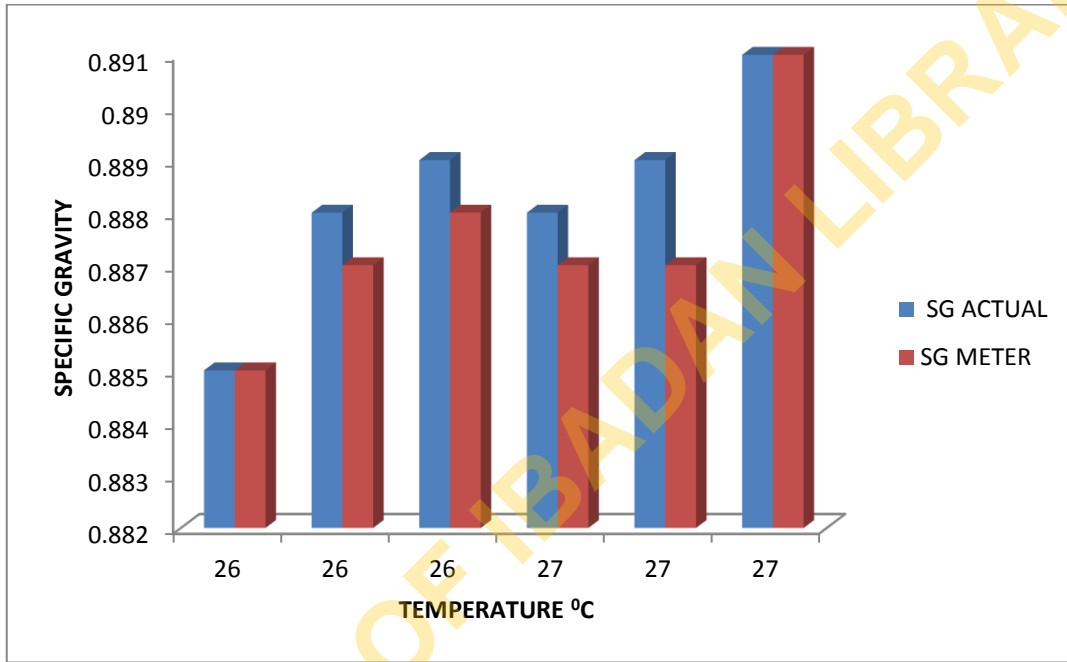

Figure 4.26: Specific Gravity versus Temperature of Diesel/Saw dust mixture

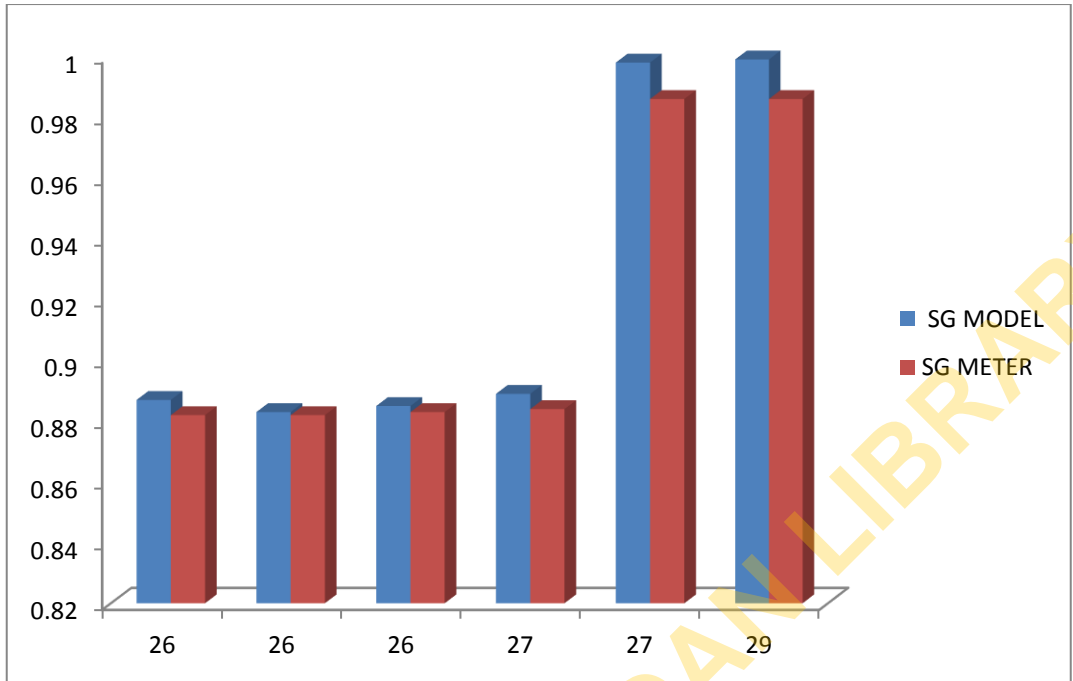

Figure 4.27: Specific Gravity versus Temperature of kerosene/Saw dust mixture

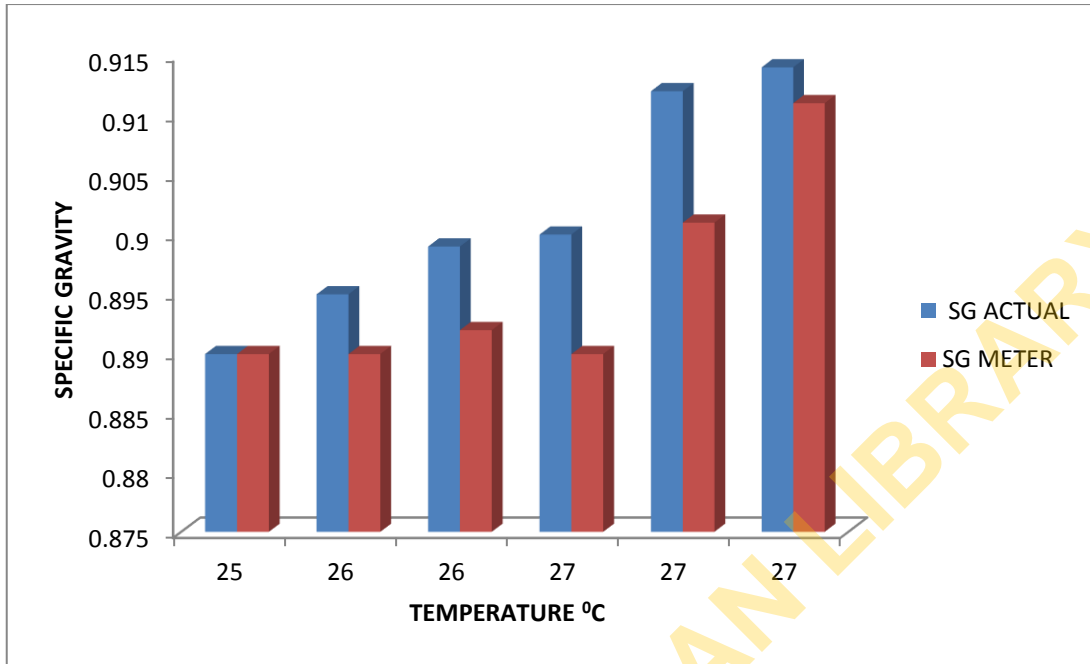

Figure 4.28: Specific Gravity versus Temperature of Petrol/Ash Oil mixture

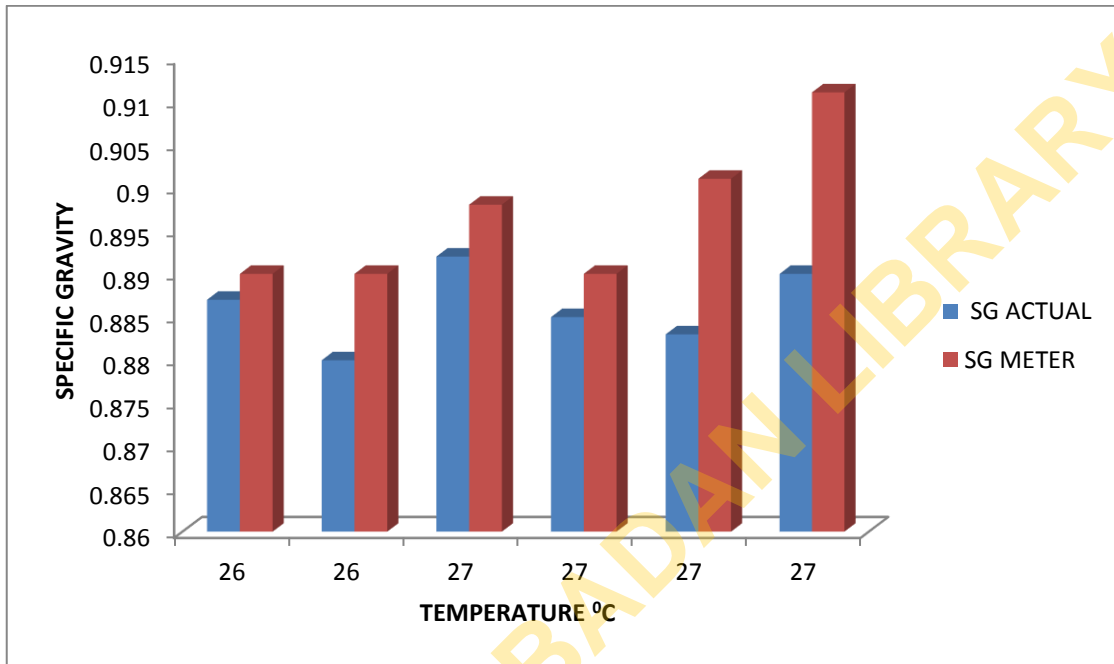

Figure 4.29: Specific Gravity versus Temperature of Diesel/Ash mixture

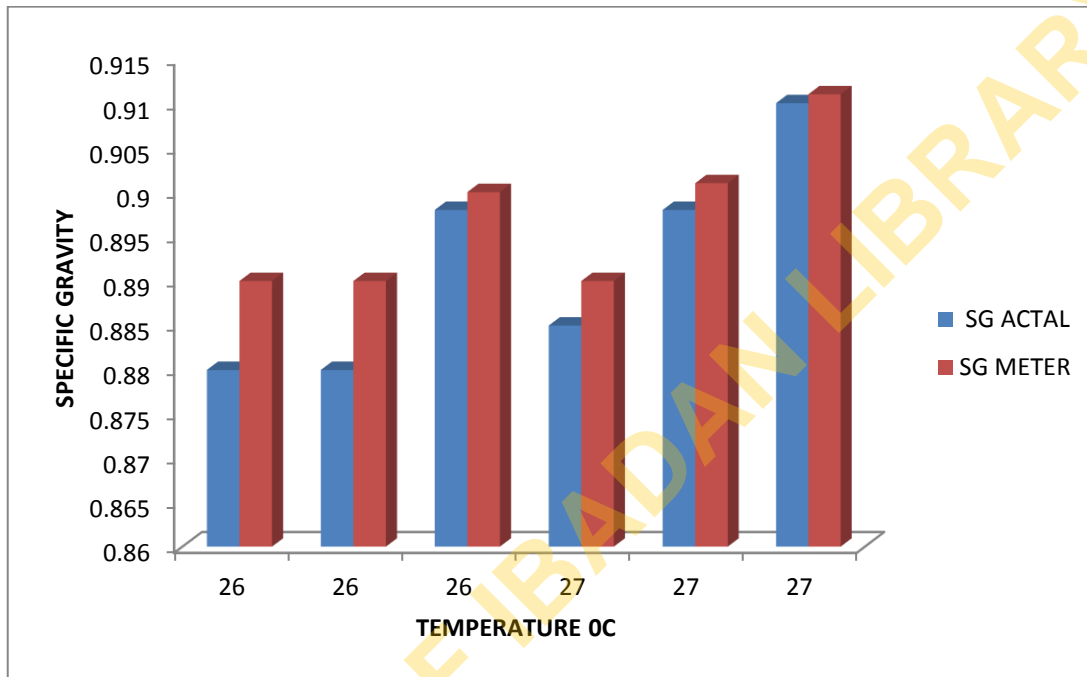

Figure 4.30: Specific Gravity versus Temperature of Kerosene/Ash mixture.

4.14 Result of Laboratory Biodegradability Test

Fig 4.31 shows the graphical representation of casing plastic (polyvinyl) when subjected to biodegradability test to ensure decomposition. The plastic sank in the mixture and after 30 days, the plastic has disintegrated in the synthetic waste forming a compost, after 60 days, the compost has degraded, its particles pass through the sieve (mesh size 2 mm) leaving some smaller particles behind and after 90 days, the compost has degraded completely leaving no particle behind.

UNIVERSITY OF IBADAN LIBRARY

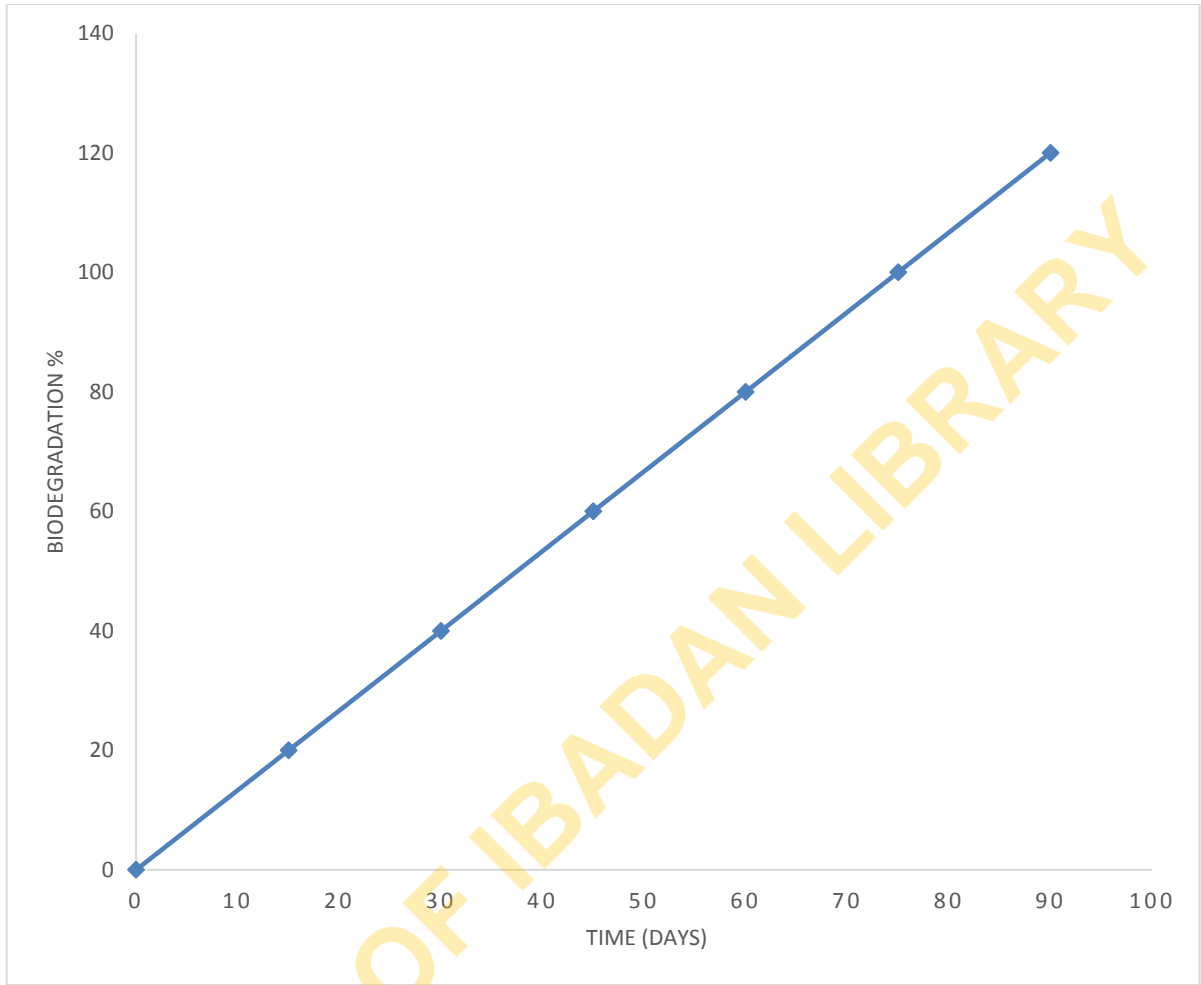

Figure 4.31: Biodegradation curve of the casing (polyvinyl sample).

4.15 Statistical Analysis

Table 4.45: Statistical Studies of Experimental Result and Models obtained .

$$\% \text{ error} = |x \text{ measured} - x_{\text{true}} / x_{\text{true}}| \cdot 100\%$$

Sample	SGACTUAL ($\sum X_i / N_i$)	SGMODEL1 ($\sum X_i / N_i$)	%ERR	SG METER ($\sum X_i / N_i$)	%ERR	SG MIXING RULE ($\sum X_i / N_i$)	%ERR
A	0.852	0.824	0.002	0.850	0.002	0.853	0.001
B	0.988	0.935	0.004	0.982	0.001	0.984	0.004
C	0.895	0.823	0.003	0.896	-0.001	0.894	0.005
D	0.985	0.940	-0.005	0.983	0.001	0.985	0.001
E	0.950	0.885	0.005	0.990	0.004	0.949	0.001
F	0.983	0.980	0.005	0.983	0.001	0.984	0.001
G	1.003	0.995	0.023	1.002	0.001	1.004	0.001
H	0.950	0.945	0.004	0.950	0.000	0.950	0.001
I	0.923	0.968	-0.004	0.924	-0.001	0.922	0.001
J	0.980	0.996	-0.003	0.981	0.001	0.980	0.001
K	0.995	0.975	-0.002	0.995	0.000	0.994	0.001
L	0.884	0.881	0.002	0.880	0.002	0.885	0.001
M	0.992	0.957	-0.003	0.988	-0.001	0.991	0.001
N	0.950	0.950	0.001	0.950	0.001	0.953	0.003
O	0.868	0.883	-0.003	0.883	-0.001	0.865	0.003
P	1.060	1.080	-0.002	1.060	0.001	1.059	0.001
Q	0.930	0.990	-0.002	0.980	-0.001	0.931	0.001
R	0.860	0.872	-0.002	0.865	0.003	0.862	0.002
S	0.940	0.933	-0.002	0.950	-0.001	0.938	0.002
T	0.980	0.889	-0.001	0.980	-0.001	0.978	0.002
U	0.880	0.885	0.001	0.884	-0.001	0.881	0.001
V	0.860	0.880	0.001	0.860	-0.001	0.856	0.004
W	0.930	0.901	-0.001	0.940	-0.002	0.929	0.001
X	0.990	0.990	0.001	0.940	-0.002	0.989	0.001

4.16 Frequency for the Adulterate Meter with Proteus using Simulation Windows.

The microcontroller in this circuit was programmed with c codes. The μ vision4 c compiler was used for this purpose. The compiler was used to generate the hex files which were burnt into this chip. The chip (microcontroller) without these hex files is dormant, meaning that it cannot execute any task. The program for this chip was carefully written and properly debugged before the hex files was the burnt to the chip. Below are the exact c codes for the microcontroller.

UNIVERSITY OF IBADAN LIBRARY

Figure 4.32: Microcontroller C Codes

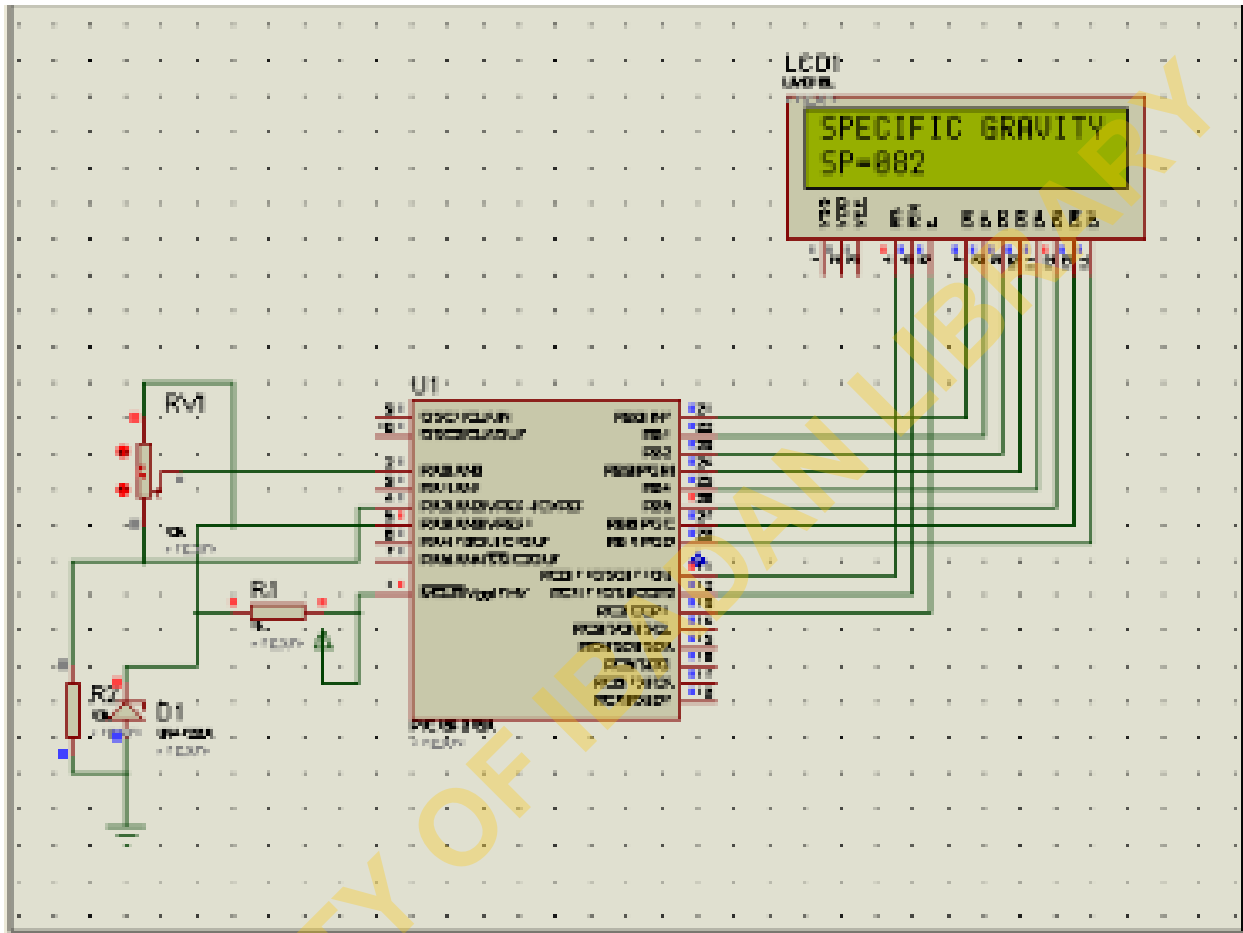

CHAPTER FIVE

SUMMARY, CONCLUSION AND RECOMMENDATIONS

5.1 Summary

The study has shown that the design of a simple and cheap device that can make real-time detection of petroleum products adulterated between 23-28°C by selected liquid and particulate solids can be developed using the physiochemical properties of the sample. The new developed device termed an Adulterate meter, was made up of an eco-friendly biodegradable material as the casing so as ensure a more user friendly device.

Specific gravity and ITF of adulterated fuel sample were detected using Kay- mixing rule technique and the result compared with the experimental/actual readings. It was observed that the specific gravity as it varies with interfacial tension was highly significant in detecting adulteration. Specific gravity alongside the ITF increased with an increase in the volume of adulterant at ambient temperature, the specific gravity obtained from the kay mixing technique has little or no difference with the actual measurement especially after the introduction of the adjustment factor.

The Adulterate meter was tested and evaluated and was proven effective. This was carried out by varying the concentration of each sample with a known quantity of an adulterant that is readily available: They include Water, Petrol, Kerosene, Diesel, Naphtha, lubricating oil, Heavy oil (Used Lubricating oil), Fuel oil (From Polyethylene), Industrial Solvent (Alcohol), Sand dust, Sawdust, and Ashes. Adulterate meter readings were all accurate.

The Specific gravity values obtained from the developed by Olotu 2018 were validated using the actual readings and then, compared with the adulterate meter readings. It was observed that undoubtedly, the device detected petroleum products adulteration by giving

a visual signal. The signal is in the form of a specific gravity digital display and light-emitting diode LED colour display.

5.2 Conclusion

From the generated experimental and mathematical modelling data, and numerical simulation, it can be concluded that the new developed device called Adulterate meter detected adulteration between 20 - 40% concentration by volume of liquid contamination and 10 - 30% concentration by mass of Solid contamination. Adulterate meter was made of microcontroller of PIC16f876 microchip with a multiple input/ output pins which was embedded in a casing made of a biodegradable polyvinyl plastic, the casing was tested and proven to disintegrate in the space of 90days. It could also be inferred that the device is ideal for both the elite and illiterate as the specific gravity reading works for the elite and the colour indicator for the illiterate. The device has been developed to solve fuel Adulteration problems in the environment, particularly in Nigeria.

5.3 Recommendations

The following recommendations were made from finding in the process of carrying out this work:

1. The principles adopted in this study be applied using relative permittivity and dielectric current to determine the degree of adulteration of fuel. The two parameters should form a basis for the simulation of a new design.
2. Studies should also be carried out on detecting gas adulteration, using the gas's physical and chemical properties. An appropriate study has to be carried out in other likewise to ascertain the prevalence of gas adulteration in society and the suitable solution has to be provided.

5.4 Contributions to Knowledge

The findings from this study had been able to add the following contributions to knowledge.

1. A quick and handy monitory device that can monitor fuel quality and adulteration in real -time and at the distribution point has been developed. This undoubtedly will provide a total dependability on fuel production in the country.
2. The new developed technology has provided a solution to the life threatening occurrences emanating from fuel adulteration.
3. The use of the device has also made the laboratory analysis of fuel adulteration detection which is time consuming to be addressed, such that the quality assurance of fuel industrially can now be done with ease.

5.5 Suggestions for Further Studies

1. Further studies are suggested to be carried out especially in the study of other forms of contamination in the Food Sector, Health, Chemical and Agro-allied Industries.
2. Appropriate tool to detect Impurity/adulteration using similar binary mixture should be developed and fabricated accordingly.

REFERENCES

- Arankalle, A., R 2003., "Monitoring Fuel Adulteration Automotive Research Association of India, 3(4):3, pp1915-1922.
- Adesina S. F, Joy ,E.C, Gbadegehin A. A.2020. A fast and cost-efficient method to detect ethanol as adulterant in gasoline, Published online, Journal of MethodsX7(2020) 100974 , doi: [10.1016/j.mex.2020.100974](https://doi.org/10.1016/j.mex.2020.100974)
- Baudo, R. 1990. Sediment sampling, mapping and data analysis. Sediments: Chemistry and Toxicity of In-Place Pollutants. Lewis Publishers, Ann Arbor, MI, pp 15–60.
- Cuckow, F.W. 1994. A new method of high accuracy for the calibration of reference standard hydrometers. J. Soc. Chem. Ind. Research, 68, 44–49.
- Danesh, A., Fonseca, M., 2005. Physical and Rheological Behavior of High-Pressure/High-Temperature Fluids in Presence of Water, SPE 94068 Proceedings of the 22th Annual Conference of the Society of Petroleum Engineers, Nigeria. pp 91-97.
- Dauda, M. R., 2012. Impact of motor parks on the concentration of heavy metals in some selected urban areas of Benue State Nigeria, Der Chemical Silica, 3(3),745-752.
- Eskay, O.K. 2018. Adulteration of Petroleum Products in Nigeria. Nigeria Tribune. Retrieved August 4,2018, <http://www.ngtribune.com>.
- Garrett, T.K. 1994 Automotive Fuels and Fuel Systems, Vol. 2: Diesel, London: Pentech Press.
- Ibrahim K. 2008; "Frequency Measurement", Creative Press, USA.
- Isehunwa, S. O. and Falade, G. K. 1993. A Type Curve Approach to Quantitative Description of Reservoir Fluids. Paper SPENC 9309, Proceedings of the 17th Annual Conference of the Society of Petroleum Engineers, Warri, Nigeria. Pp 91-97.

- Isehunwa, S. O. and Olanisebe E. B. 2015. Estimation of the refractive indices of some binary mixtures. *African Journal of Pure and applied Chemistry*, Vol.9(4). 58-64.
- Isehunwa, S. O. and Udeagbara S.G., 2011. Effect of Temperature and contamination on the Surface Tension of Niger Delta Crude Oils. *Australian Journal of Basic and applied sciences* ,Vol.5(4). 610-617.
- Isehunwa, S. O. and Adeboye O. A. , 2012. Interfacial Tension of crude oil Brine system in the Niger Delta. *International Journal of research and reviews in applied sciences*.Vol.10 No 3. 460-467. ISSSN 2076-734 X
- Jane.,1986 . Field and laboratory testing of sediment and water in crude oil. Savant measurement corporation, TX, USA.
- Jersha, F, Purohitam A.,Udaykiran 1.,2015, Fuel Adulteration Detection System, *Indian Journal of Science and Technology*, Volume 8(2), pp90-95.
- Jersian V., 2015, Fuel Adulteration Detection System *Indian Journal of Science and Technology*, Vol. 8(S2), 90-95, January 2015 USA.DOI: 10.17485/ijst/2015/v8iS2/59076.
- Jude, C, Igwe, E., Kalu, A., Kashefi, L. 2012. Extraction, characterization and determination of ethanol fuel composite qualities, *Asian journal of plant science and research*, 2(5), pp 643-649.
- Kude, V. P. and Patil, A 2017. Detection of Fuel Adulteration in Real Time Using Optical Fiber Sensor and Peripheral Interface Controller. *Int. Journal of Optics and Photonics*, Vol. 11 (2) pp 95-102.
- Kashefi. L., Jude, C., Igwe, E., Kalu, A., 2012. Extraction, characterization and determination of ethanol fuel composite qualities. *Asian journal of plant science and research*, Vol. 2 (5), pp 643-649.
- Lurenza, C., Giovanna, J, 2010. A predictive thermodynamic model for the Brazilian gasoline, *fuel*, 84, 1099-1104.

- Mishra, V, Jain SC, Singh N, Poddar GC, Kapur P. 2008 . Fuel adulteration detection using long period fibre grating sensor technology. *Indian J Pure Applied Phys.*; 46:106–110.
- Nikos, P. G. Vasilis, 2006 Octane number prediction for gasoline blends, *Fuel processing technology*, 87(6), 505–509.
- Noor A. M. , 2016 Octane number prediction for gasoline blends, *Fuel processing technology*, 87(6), 505–509.
- Olotu, O.O ,2018 Development of a model for detection of Petroleum products adulteration, Unpublished M Phil .Dissertation, University of Ibadan.
- Olanisebe E. B. ,Isehunwa S.O 2013. Effect of pH on Interfacial Tension and crude oil-water emulsion resolution in the Niger delta. *Journal of Petroleum and Gas Engineering*, Vol.4(8). 198-202.
- Otega E,and Gods will O. 2020. Automated Volume Measurement , Adulteration Detection and tracking of Petroleum Products.. Paper SPE 203694MS, Proceedings of the 17th Annual Conference of the Society of Petroleum Engineers, Lagos, Nigeria. Pp 91-97.
- Owen, Keith and Coley, Trevor 1995. *Automotive Fuels Reference Book, 2nd Edition*. Warren dale, Pennsylvania: Society of Automotive Engineers.
- Paul T. 2004; “Physics for Scientists and Engineers; Electricity, Magnetism, Light and Elementary Modern Physics, Freeman publishers, USA.
- Pettit,T.S., ;Irga P.J, Air Quality, Atmosphere & Health. Volume 12,No 1, 33-44
- Picard, A.; Davis, R.S.; (2018) Revised formula for the density of moist air (CIPM-2007). *Metrologia*, 45, doi:10.1088/0026-1394/45/2/004.
- Srikanth,P.C., Madhu.,D. (2018) *International Journal of Engineering Research in Electronics and Communication Engineering (IJERECE)* Vol. 5, Issue 2, pp61-63.
- Remy Uche,(2012), Design and development of water-in-fuel detector Vol 3, No 10.33-45

- Roy, S. (1999) , Fibre optic sensor for determining adulteration of petrol and diesel by kerosene. *Sensors and Actuators*, 55, 212–216.
- Roland, S (2001)., *Advanced control Engineering, (1st Edition)* Oxford Auckland Boston Johannesburg Melbourne New Delhi, pp 16-30
- Sengupta, A. K. and Sharma, R. K. (2010). A new method for estimation of automobile fuel adulteration, air pollution chapter 16, Vanda Villainy (Ed.), Intech Publishers, pp357-370.
- Sergey V. S (2011)- Melamine Analysis in Liquid Milk by Simple and Robust Neural Network Based Method, *I.J. Education and Management Engineering*, 3, 24-30.
- Susan, J (2018) Different types of light emitting diodes(LED)materials and challenges. *International Journal of research in Applied science and Engineering Technology*. Volume 6, 33-39.
- Tiwale, S. D., Prasad, A., Milind, G., Prakash, G. and Nishant, K. (2013). *International Journal of Advanced Research in Electronics and Communication Engineering(IJARECE)* Volume 2, Issue 1.
- Takemi, S., (2016). *Intech open's Journals, London, SW72QJ*, Volume 4, Issue 1.
- Urena M, (1999). Adulterated Fuel pushes up pollution dramatically, survey of Information guide in Nigeria. *Daily Vanguard*. Retrieved August 1, 2018, <http://www.ngdailyvanguardnigeria.com>.
- Usha M.T, S. T., Ramakrishna KA (2003). Study on Automobile Exhaust Pollution with Regard to Carbon Monoxide Emissions. *Environ. Pollution. Technology*, 2(4) 473 - 474.
- Vicente, C.; Yao, W.; Maris, H.; Seidel, G. (2002), Surface tension of liquid as measured using the vibration modes of a levitated drop, *Physical Review B* 66 (21).
- Website of Anti adulteration cell, [www. Anti adulteration cell. com](http://www.AntiAdulterationCell.com). Government of India, "Report of the Expert Committee on Auto Fuel Policy".

- Willy L.S.M. (2013) 'Adulteration Detection of Brazilian Gasoline Samples by Statistical Analysis', Elsevier Fuel-84, p. 467-473.
- William L. Luyben (1996) Process modelling, Simulation, and Control for Chemical engineers McGraw-Hill Publishing Company, International Edition.
- William M. H, (1998) "Signals, Sound, and Sensation", Springer-Verlag New York.
- World Bank report July 2002 'South Asia Urban Air Quality Management Briefing Note no. 7', available at <http://www.worldbank.org/saurbanair>.
- World Bank Publications,(2001) Pollution management in Focus, Discussion note, "Transport fuel taxes and urban air quality". Centre for Science & Environment, New Delhi, Retrieved February 2002,
- World bank report (2001), 'Transport Fuel Taxes and Urban Air Quality', Pollution Management in Focus Discussion Note No.11, available at <http://www.worldbank.org/essd/essd.nsy/>.
- World bank report (Dec. 2001) 'Transport Fuel Taxes and Urban Air Quality', Pollution Management in Focus Discussion Note No. 11, available at <http://www.worldbank.org>
- World bank report (2001) "Abuses in Fuel markets", viewpoint note no. 237, available at <http://www.worldbank.org/html/fpd/notes/237/237kojim-831.pdf>.
- Yadav, S. R., Murky, V. K., Mishra, D. and Baral B. (2005). Estimation of Petrol and Diesel Adulteration with Kerosene and assessment of Usefulness of Selected automobile fuel quality test parameters. In. Journal of Environmental. Science and Tech. Vol 1 (4) pp 253-255.

APPENDIX

COMPUTER SIMULATION FOR ASSEMBLING LANGUAGE IN HEXADECIMAL

Hexadecimal is the term commonly used by computer system designers and programmers. They provide a more human-friendly demonstration of binary-coded values. Each hexadecimal digit means four binary digits, which can also be called a nibble, which is half a byte. The hexadecimal result of the programming language becomes:

:020000001228C4

:06000A008207303431349E

:100010003234333434343534363437343834393494

:100020002A342334850186018701C501C401AB014F

:10003000AC01C6018316031388309F00831203139B

:1000400083160313FF3085000030860000308700E0

:1000500083120313E630D620071087103F30860046

:10006000D0201530D6203F308600D020DB203F3016

:100070008600D020DB203B308600D020E0200830F6

:100080008600D020E02001308600D0200930D62024

:1000900002308600D0200930D6200C308600D020D7

:1000A000E02006308600D020E02083120313413088

:1000B0009F00E520F6200710871001308600D02031

:1000C0000930D620071487105330A7205030A720BE

:1000D0004530A7204330A7204930A7204630A7202D

:1000E0004930A7204330A7202030A7204730A72041

:1000F0005230A7204130A7205630A7204930A720F2
:100100005430A7205930A7202030A720071087108F
:10011000C030A720071487105330A7205030A720E5
:100120003D30A7202E08BD002D08BE00AB204108A1
:100130000520A72042080520A72043080520A72066
:100140002030A7202030A7201221552855288600CE
:10015000D020E02008003D08F038C200C207C207E6
:10016000C100FB3EC107293EC3003E0EF038C20766
:10017000C307C30DC309C30D3E080F39C307C20D22
:100180000530C0000A30C307C203031CC328C207DE
:10019000C103031CC728C107C003031CCB280800E8
:1001A0000711E0200715E02007110800B000DB2050
:1001B000B00BD7280800C830AF00AF0BDD2808000F
:1001C0003230AF00AF0BE228080005211F151F19C0
:1001D000E728831203131E0883120313C400831637
:1001E00003131E0883120313C50008004508AD0061
:1001F0004408AE0008004508AC004408AB00080005
:10020000C830A000A00B022908000030A100053072
:10021000A2006430A300A30B0B29A20B0929A10B98
:10022000072908000A30A400FF30A500FF30A6000F
:0E023000A60B1829A50B1629A40B14290800EB

:02400E00713F00

:00000001FF

-

PROGRAMMING ALGORITHM FOR THE MATHEMATICAL MODEL

Algorithm for the changes in Specific Gravity and Temperature with ITF, which will be computed on the Microcontroller was developed for model 1 because it's the most suitable compared to the actual data.

STEP 1: START

STEP 2: DECLARE B AS FLOAT

DECLARE pa' AS FLOAT

DECLARE pcal FLOAT

STEP 3: SET pcal=8000KGM^3

STEP 4: INPUT THE VALUE OF pa'

STEP 5: B=1-pa/pcal

STEP 6: OUTPUT THE RESULT B

STEP 7: STOP

STEP 1: SET $\gamma_l = \gamma_o * (1-T/T_c)$

STEP 2: SET M=M-V*pa

SET

SET

STEP 3: INPUT VALUE FOR R_a

INPUT VALUE FOR γ_l

INPUT VALUE FOR V

STEP 4: IF $p_a=0$, $v=1$,

$SG =$

STEP 5: SET $SG =$

STEP 6: OUTPUT RESULT

STEP 7: STOP

CASE 2:

STEP 1: START

STEP 2: DECLARED AS DOUBLE

DECLARE γ_l AS DOUBLE

DECLARE g AS FLOAT

DECLARE p_l AS DOUBLE

DECLARE π AS DOUBLE

STEP 3: SET $\pi=3.142$

STEP 4: SET $=0$

STEP 5: SET $=30$

STEP 6: SET $T=250C$

STEP 7 SET =1.225

STEP 8: INPUT VALUE FOR D

 INPUT VALUE FOR

 INPUT VALUE FOR g

 INPUT VALUE FOR T

STEP 5: =

STEP 6: DISPLAY RESULT

STEP 7: S ET SG=

STEP 8: IF SG <0.810 or> 0.897

STEP 9: DISPLAY GREEN

STEP 10: IF SG <0.897 or> 0.900

STEP 11: DISPLAY AMBER

STEP 12: IF SG <0.900 or> 0.990

STEP 13: DISPLAY RED

STEP 14: STOP

MODEL SIMULATION

// Console Application5.cpp : Defines the entry point for the console application.

```
#include "stdafx.h"
```

```
#include<iostream>
```

```

#include<iomanip>

z int _tmain

this program calculate the calibration factor for the balance

    double B;

    double pcal,paa;

    pcal=8000.00;

    std::cout<<"air density during balance calibration, pa'="<<"\n";

    std::cin >> paa;

    B=1-paa/pcal; //this simulate calibration factor

//    std::cout<<fixed<<B <<"\n";

    std::cout<<std::set precision(3)<<B<<"\n"; //display the digital value for calibration
factor

// Case 1: Hydrometer calibration in an hydrocarbon liquid of unknown specific gravity 1:

    double D,yl,g,pl,pi;

    double u,pa,V,m;

    std::cout<<"Enter the value for pi="<<"\n";

    std::cin>>pi; //value for pi

    std::cout<<"diameter of the stem at scale reading ="<<"\n";

    std::cin>>D; //value for diameter of the stem at scale reading

    std::cout<<"surface tension of liquid to be measured ="<<"\n";

```

```

std::cin>>y1; // surface tension of liquid to be measured

std::cout<<"local acceleration of gravity ="<<"\n";

std::cin>>g; // local acceleration of gravity

std::cout<<"density of calibration liquid ="<<"\n";

std::cin>>pa; //density of calibration of liquid

std::cout<<"immersed volume of the hydrometer="<<"\n";

std::cin>>V;

std::cout<<"non-immersed volume of the hydrometer="<<"\n";

std::cin>>u;

std::cout<<"mass="<<"\n";

std::cin>>m;

pl=(m+(pi*D*y1)/g-(u*pa))/V; // calibration in an hydrocarbon liquid of unknown density

std::cout<<"calibration in an hydrocarbon liquid of unknown"<<std::set
precision(3)<<pl<<"\n";

// calibration in an hydrocarbon liquid of unknown

// Case 2: Hydrometer calibration in air :

double Ra;

std::cout<<"input the balance reading ="<<"\n";

std::cin>>Ra; //value for balance reading

```

```
pa=B*Ra/m-(V+u); // Hydrometer calibration in air.
```

```
std::cout<<std::set precision(3)<<pa; // Hydrometer calibration in air ?a
```

```
// Case 3: Hydrometer calibration in a standard liquid specifically pure water of known  
specific gravity.
```

```
double Rs,ys,ps;
```

```
double pl,SG;
```

```
std::cout<<"balance reading of suspended hydrometer="<<"\n";
```

```
std::cin>>Rs; // balance reading of suspended hydrometer
```

```
std::cout<<"surface tension of calibration liquid="<<"\n";
```

```
std::cin>>ys; //the surface tension of calibration liquid
```

```
std::cout<<"density of calibration liquid="<<"\n";
```

```
std::cin>>ps; //density of calibration of liquid
```

```
ps=(m+(pi*D*ys)/g-B*Rs-u*pa)/V;
```

```
std::cout<<std::setprecision(3)<<ps; // ?s
```

```
pll=(Ra*ps-Rs*pa)/Ra-Rs;
```

```
SG=pll/ps;
```

```
if(SG < 0.800 || SG >= 0.999){
```

```
    std::cout<<"RED"
```

```
else if (SG == 0 || SG==1)
```

```
std::cout<<"GREEN";

std::cout<<"Surface temperature varies " <<std::set precision(3)<<pll;

//std::cout<<p11; //

//std::cout<<pll; // return 0;
```

UNIVERSITY OF IBADAN LIBRARY